

Semantic Interaction for Narrative Map

Sensemaking: An Insight-based Evaluation

Brian Keith, Fausto German, Eric Krokos, Sarah Joseph and Chris North

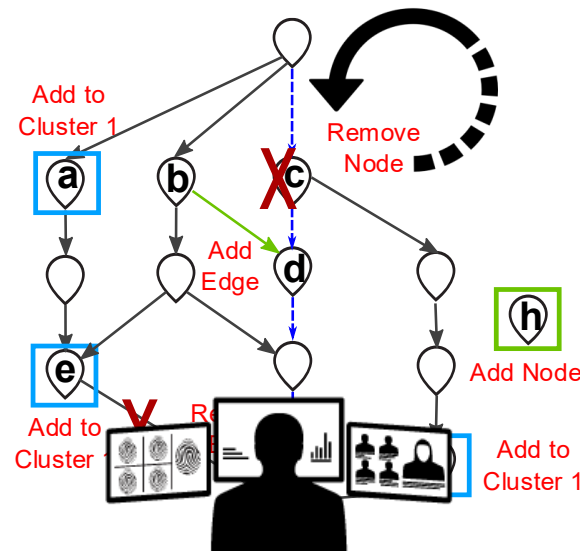

Contents

Introduction

Semantic Interaction Pipeline

Insight-based Evaluation

Conclusions





Data Set



Starting Point

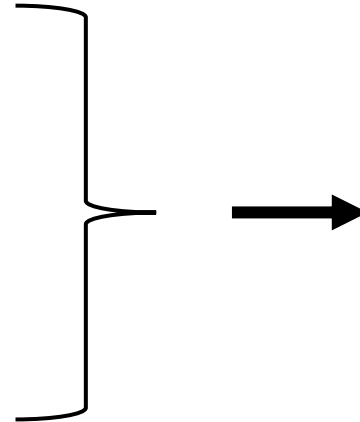

*Understand the underlying stories
and the overall narrative*

As the world vies for vaccines, Cuba's making its own

Cuban cooks overcome shortages with ingenuity on Facebook

By ANDREA RODRIGUEZ

Analysis: Cuban Communists under pressure to accelerate economic reforms

By Marc Frank

Havana goes back into lockdown after record number of COVID-19 cases in Cuba

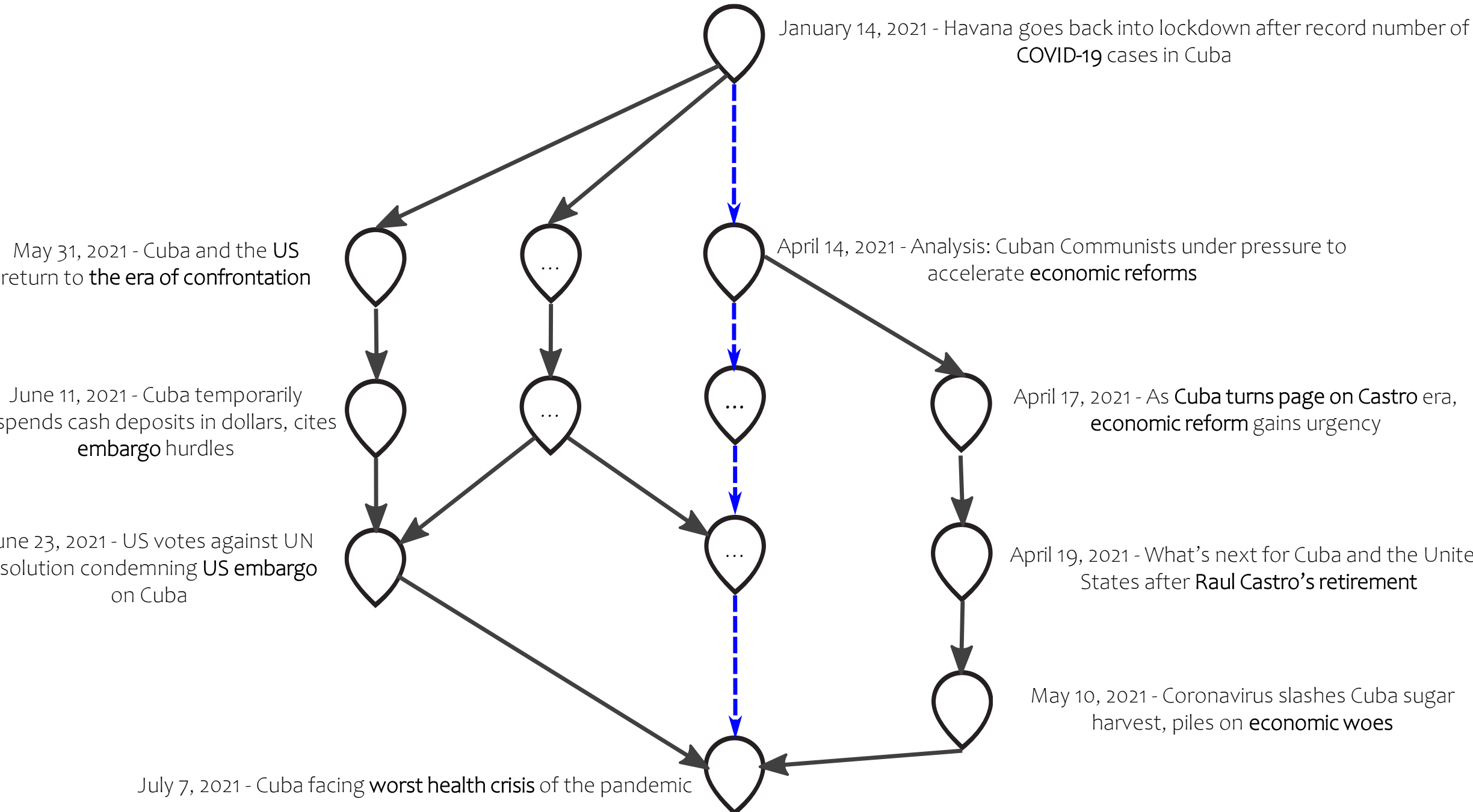

Refining Storylines

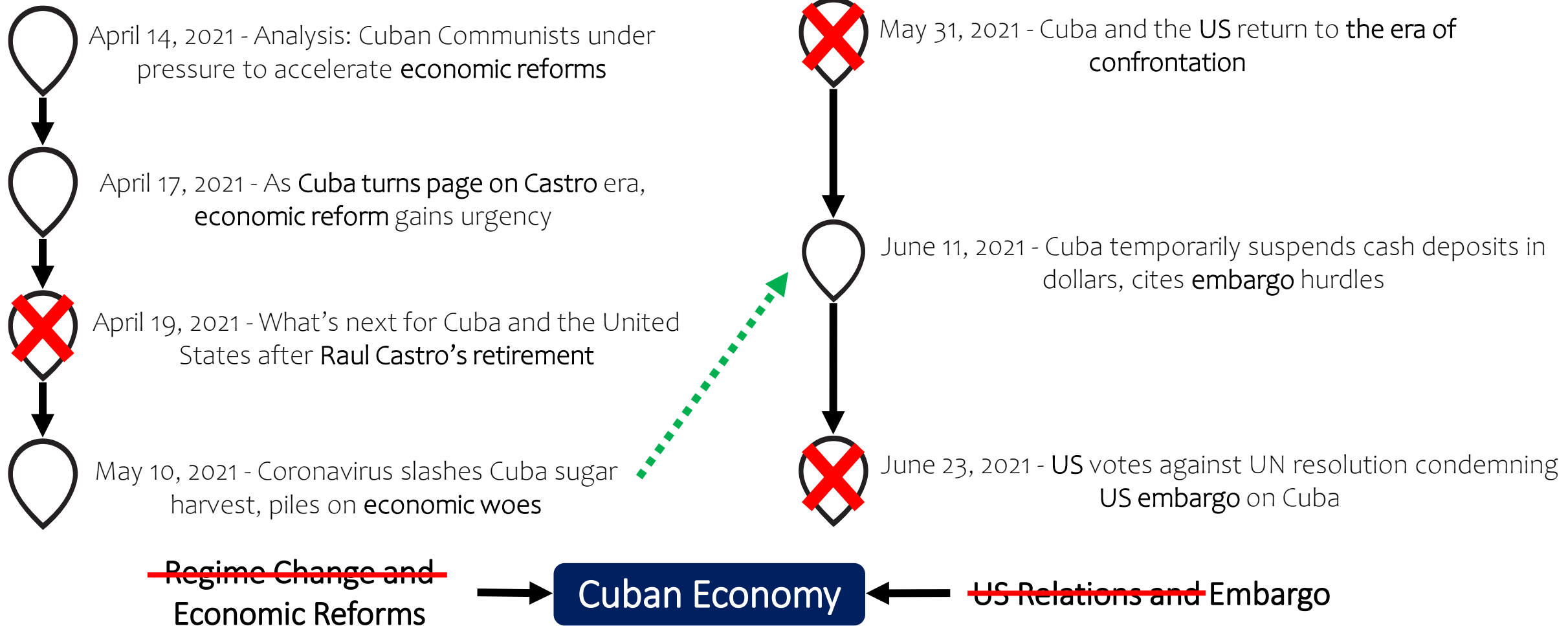

Interactive AI Model

Semantic Interaction

Semantic Interaction

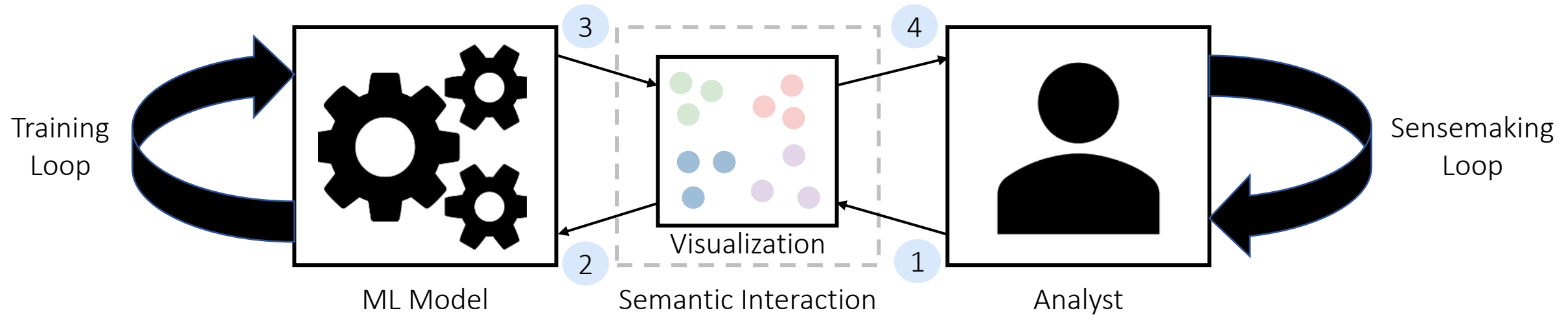

Semantic Interaction Pipeline

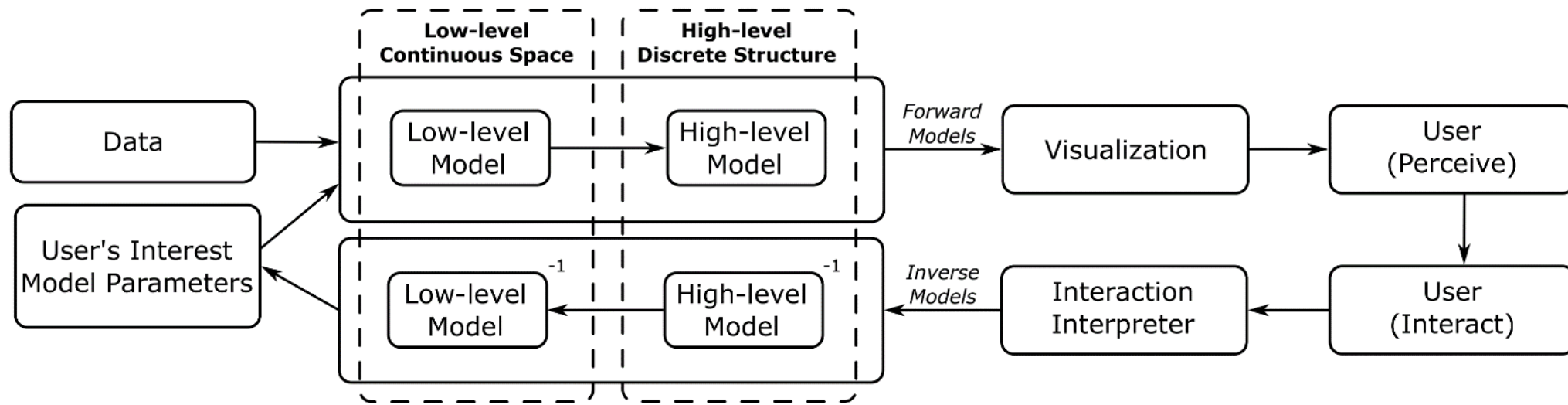

Keith Norambuena, B. F., Mitra, T., & North, C. (2023, March). Mixed multi-model semantic interaction for graph-based narrative visualizations. In *Proceedings of the 28th International Conference on Intelligent User Interfaces (IUI 2023)*



Usa EL PAIS

Cuba sees one of the biggest protests against the government since the crisis of the 1990s

Thousands of people all over the country came out to demonstrate on Sunday, amid a situation of shortages and hardships that has been exacerbated by the pandemic. More than a hundred arrests were made

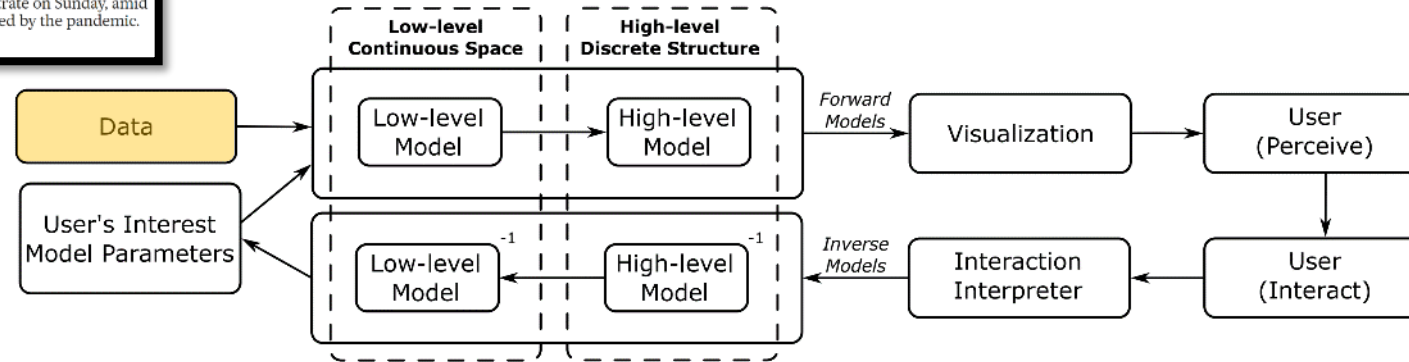



Usa EL PAIS

Cuba sees one of the biggest protests against the government since the crisis of the 1990s

Thousands of people all over the country came out to demonstrate on Sunday, amid a situation of shortages and hardships that has been exacerbated by the pandemic. More than a hundred arrests were made

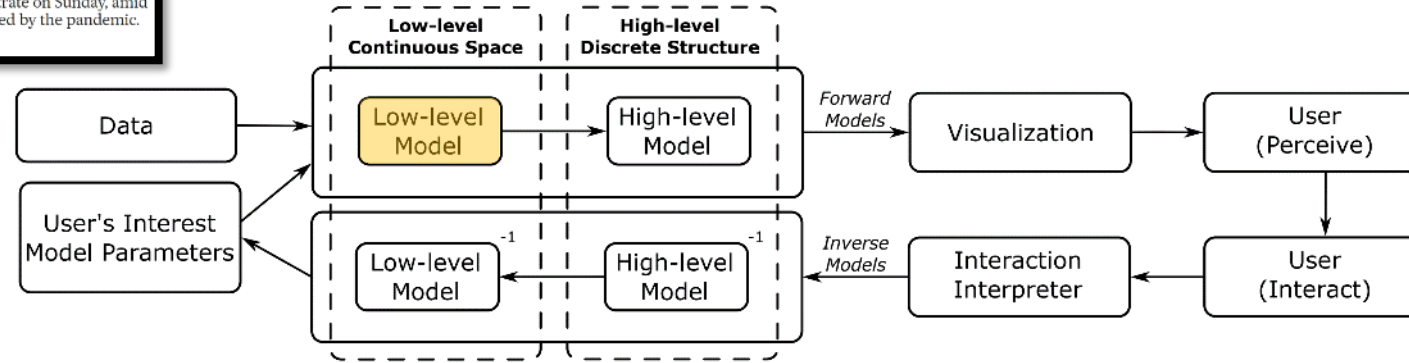
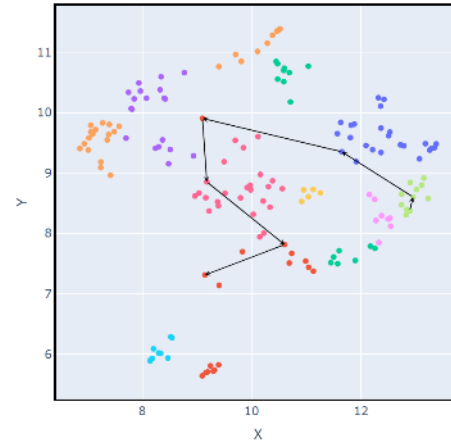



Usa **EL PAIS**

Cuba sees one of the biggest protests against the government since the crisis of the 1990s

Thousands of people all over the country came out to demonstrate on Sunday, amid a situation of shortages and hardships that has been exacerbated by the pandemic. More than a hundred arrests were made

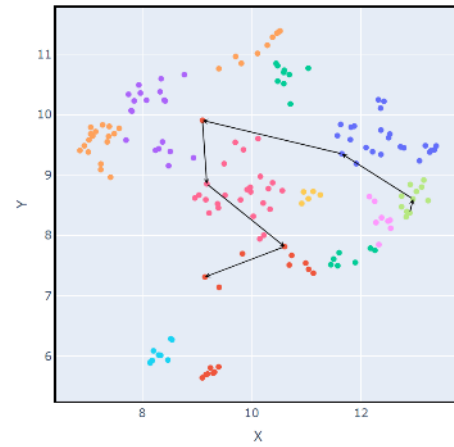

$$\begin{aligned} \max \quad & \text{minedge} - \lambda \cdot \sum_{i,j} \text{edge}_{i,j} \\ \text{s.t.} \quad & \text{minedge} \leq 1 - \text{edge}_{i,j} + \text{coherence}_{i,j} \quad \forall_{i,j} \quad [\text{Objective}] \\ & \text{node}_k = 1 \quad [\text{Fixed Start}] \\ & \text{node}_i = 0 \quad \forall_{i < k} \quad [\text{No Previous Starts}] \\ & \text{edge}_{i,j} = 0 \quad \forall_{i \geq j} \quad [\text{Chronological Order}] \\ & \sum_i \text{node}_i = K \quad [\text{Map Size}] \\ & \sum_{i < j} \text{edge}_{i,j} = \text{node}_j \quad \forall_{j \neq s} \quad [\text{Incoming Edges}] \\ & \sum_{j > i} \text{edge}_{i,j} \leq \text{node}_i \quad \forall_i \quad [\text{Outgoing Edges}] \\ \text{mincover} \leq & \frac{1}{|C|} \cdot \sum_{k \in C} \sum_{i,j} \text{edge}_{i,j} \cdot \text{membership}_{i,j,k} \quad [\text{Coverage}] \end{aligned}$$

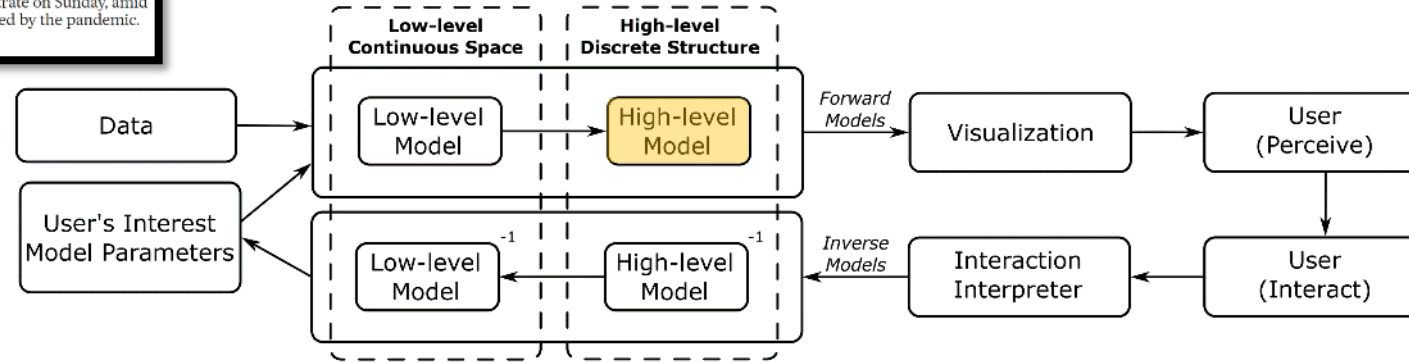



Usa **EL PAIS**

Cuba sees one of the biggest protests against the government since the crisis of the 1990s

Thousands of people all over the country came out to demonstrate on Sunday, amid a situation of shortages and hardships that has been exacerbated by the pandemic. More than a hundred arrests were made

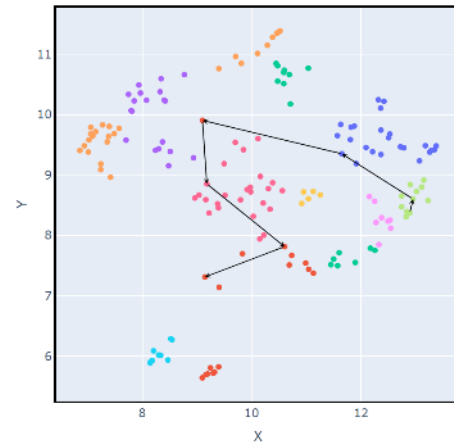

$$\begin{aligned} \max \quad & \text{minedge} - \lambda \cdot \sum_{i,j} \text{edge}_{i,j} \\ \text{s.t.} \quad & \text{minedge} \leq 1 - \text{edge}_{i,j} + \text{coherence}_{i,j} \quad \forall_{i,j} \quad [\text{Objective}] \\ & \text{node}_k = 1 \quad [\text{Fixed Start}] \\ & \text{node}_i = 0 \quad \forall_{i < s} \quad [\text{No Previous Starts}] \\ & \text{edge}_{i,j} = 0 \quad \forall_{i \geq j} \quad [\text{Chronological Order}] \\ & \sum_i \text{node}_i = K \quad [\text{Map Size}] \\ & \sum_{i < j} \text{edge}_{i,j} = \text{node}_j \quad \forall_{j \neq s} \quad [\text{Incoming Edges}] \\ & \sum_{j > i} \text{edge}_{i,j} \leq \text{node}_i \quad \forall_i \quad [\text{Outgoing Edges}] \\ \text{mincover} \leq & \frac{1}{|C|} \cdot \sum_{k \in C} \sum_{i,j} \text{edge}_{i,j} \cdot \text{membership}_{i,j,k} \quad [\text{Coverage}] \end{aligned}$$

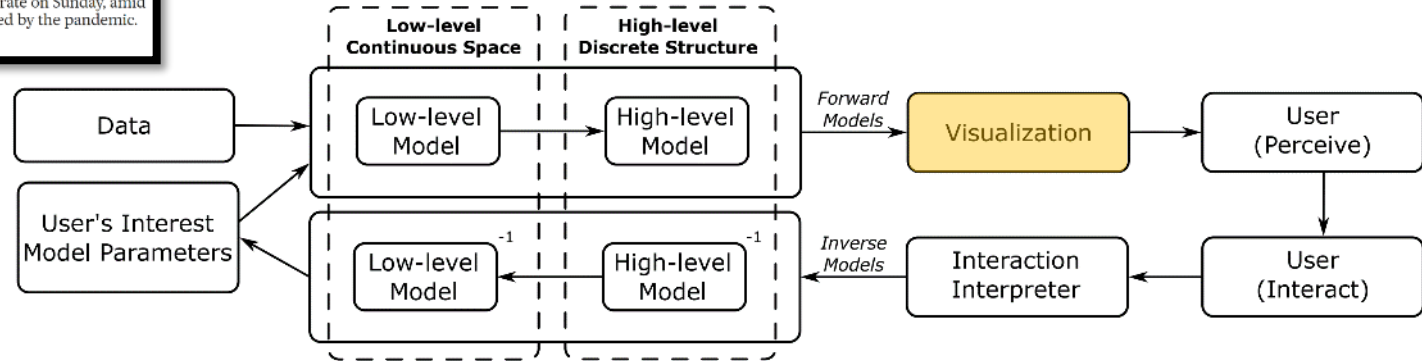
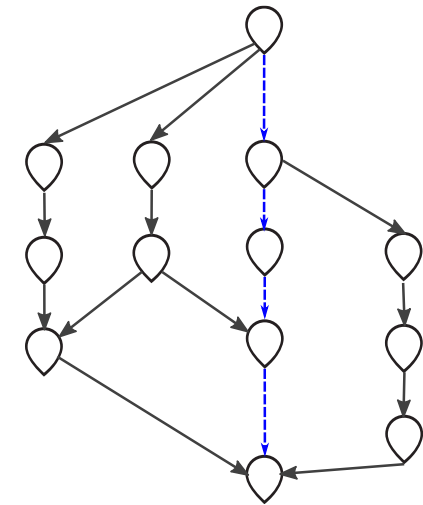



Usa **EL PAIS**

Cuba sees one of the biggest protests against the government since the crisis of the 1990s

Thousands of people all over the country came out to demonstrate on Sunday, amid a situation of shortages and hardships that has been exacerbated by the pandemic. More than a hundred arrests were made

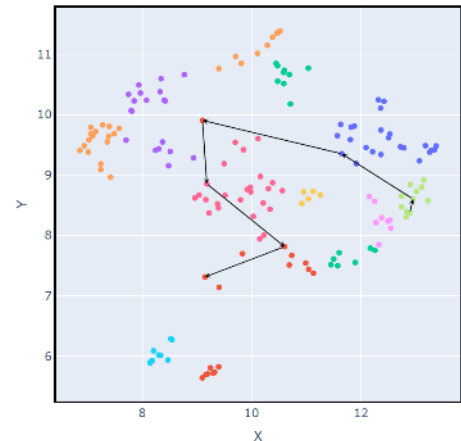

$$\begin{aligned} \max \quad & \text{minedge} - \lambda \cdot \sum_{i,j} \text{edge}_{i,j} \\ \text{s.t.} \quad & \text{minedge} \leq 1 - \text{edge}_{i,j} + \text{coherence}_{i,j} \quad \forall_{i,j} \quad [\text{Objective}] \\ & \text{node}_k = 1 \quad [\text{Fixed Start}] \\ & \text{node}_i = 0 \quad \forall_{i < k} \quad [\text{No Previous Starts}] \\ & \text{edge}_{i,j} = 0 \quad \forall_{i \geq j} \quad [\text{Chronological Order}] \\ & \sum_i \text{node}_i = K \quad [\text{Map Size}] \\ & \sum_{i < j} \text{edge}_{i,j} = \text{node}_j \quad \forall_{j \neq s} \quad [\text{Incoming Edges}] \\ & \sum_{j > i} \text{edge}_{i,j} \leq \text{node}_i \quad \forall_i \quad [\text{Outgoing Edges}] \\ \text{mincover} \leq & \frac{1}{|C|} \cdot \sum_{k \in C} \sum_{i,j} \text{edge}_{i,j} \cdot \text{membership}_{i,j,k} \quad [\text{Coverage}] \end{aligned}$$

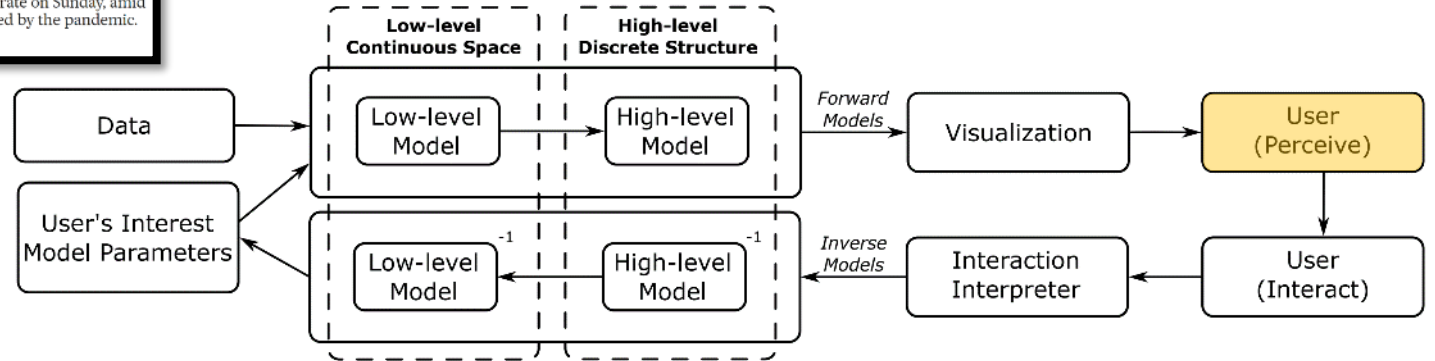
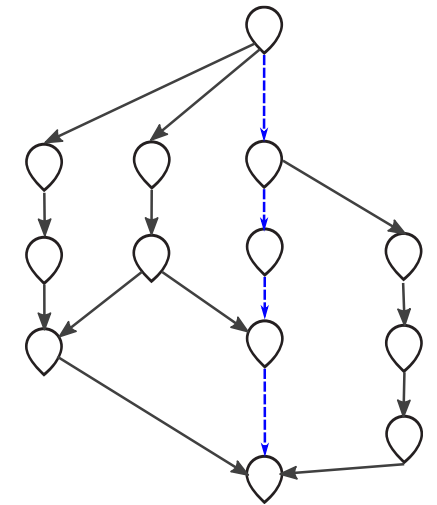



Usa **EL PAIS**

Cuba sees one of the biggest protests against the government since the crisis of the 1990s

Thousands of people all over the country came out to demonstrate on Sunday, amid a situation of shortages and hardships that has been exacerbated by the pandemic. More than a hundred arrests were made

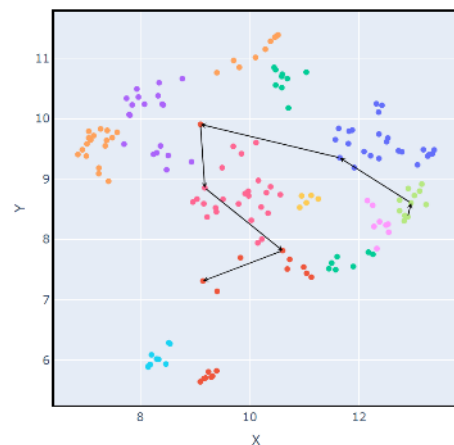

$$\begin{aligned} \max \quad & \text{minedge} - \lambda \cdot \sum_{i,j} \text{edge}_{i,j} \\ \text{s.t.} \quad & \text{minedge} \leq 1 - \text{edge}_{i,j} + \text{coherence}_{i,j} \quad \forall_{i,j} \quad [\text{Objective}] \\ & \text{node}_k = 1 \quad [\text{Fixed Start}] \\ & \text{node}_i = 0 \quad \forall_{i < s} \quad [\text{No Previous Starts}] \\ & \text{edge}_{i,j} = 0 \quad \forall_{i \geq j} \quad [\text{Chronological Order}] \\ & \sum_i \text{node}_i = K \quad [\text{Map Size}] \\ & \sum_{i < j} \text{edge}_{i,j} = \text{node}_j \quad \forall_{j \neq s} \quad [\text{Incoming Edges}] \\ & \sum_{j > i} \text{edge}_{i,j} \leq \text{node}_i \quad \forall_i \quad [\text{Outgoing Edges}] \\ \text{mincover} \leq & \frac{1}{|C|} \cdot \sum_{k \in C} \sum_{i,j} \text{edge}_{i,j} \cdot \text{membership}_{i,j,k} \quad [\text{Coverage}] \end{aligned}$$

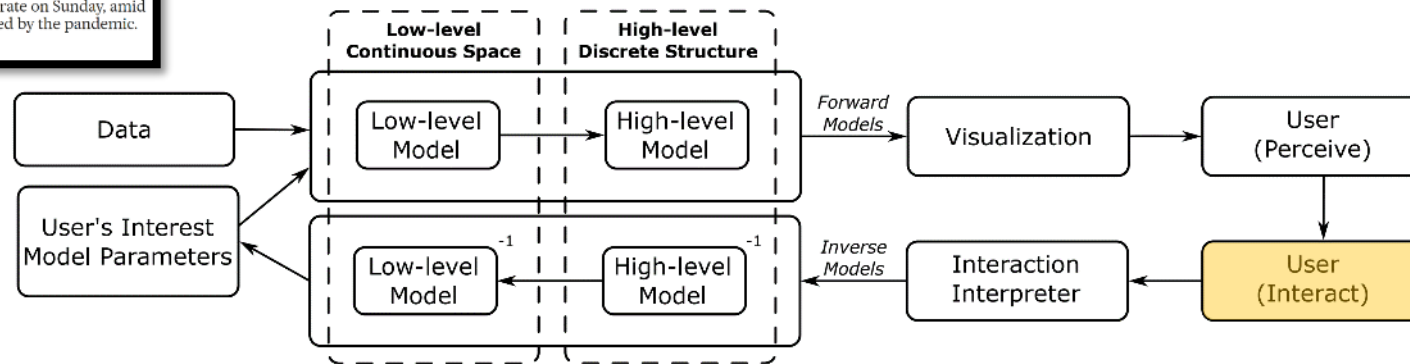
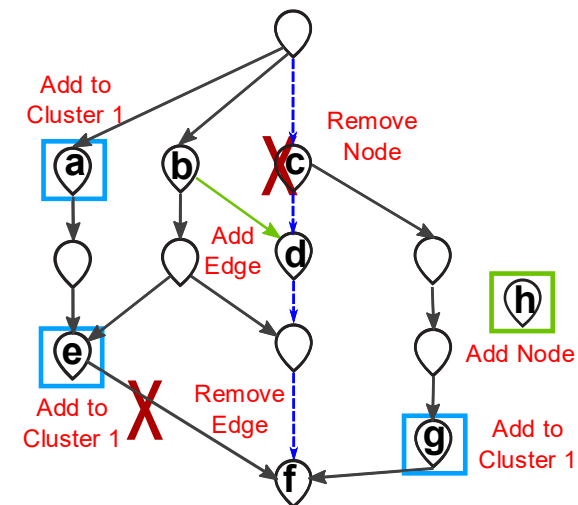

- ### User Interactions
- Grouping Events
 - Remove Event
 - Remove Connection
 - Add Event
 - Add Connection



Usa **EL PAIS**

Cuba sees one of the biggest protests against the government since the crisis of the 1990s

Thousands of people all over the country came out to demonstrate on Sunday, amid a situation of shortages and hardships that has been exacerbated by the pandemic. More than a hundred arrests were made

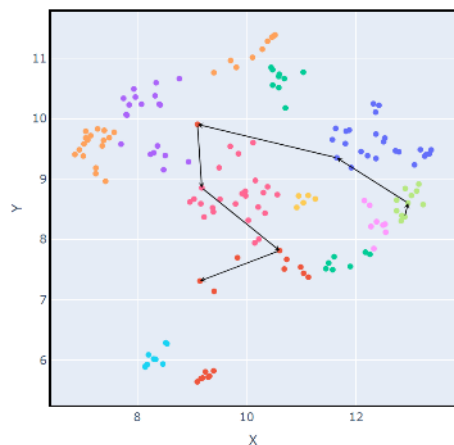

$$\begin{aligned} \max \quad & \text{minedge} - \lambda \cdot \sum_{i,j} \text{edge}_{i,j} \\ \text{s.t.} \quad & \text{minedge} \leq 1 - \text{edge}_{i,j} + \text{coherence}_{i,j} \quad \forall_{i,j} \quad [\text{Objective}] \\ & \text{node}_k = 1 \quad [\text{Fixed Start}] \\ & \text{node}_i = 0 \quad \forall_{i < s} \quad [\text{No Previous Starts}] \\ & \text{edge}_{i,j} = 0 \quad \forall_{i \geq j} \quad [\text{Chronological Order}] \\ & \sum_i \text{node}_i = K \quad [\text{Map Size}] \\ & \sum_{i < j} \text{edge}_{i,j} = \text{node}_j \quad \forall_{j \neq s} \quad [\text{Incoming Edges}] \\ & \sum_{j > i} \text{edge}_{i,j} \leq \text{node}_i \quad \forall_i \quad [\text{Outgoing Edges}] \\ \text{mincover} \leq & \frac{1}{|C|} \cdot \sum_{k \in C} \sum_{i,j} \text{edge}_{i,j} \cdot \text{membership}_{i,j,k} \quad [\text{Coverage}] \end{aligned}$$

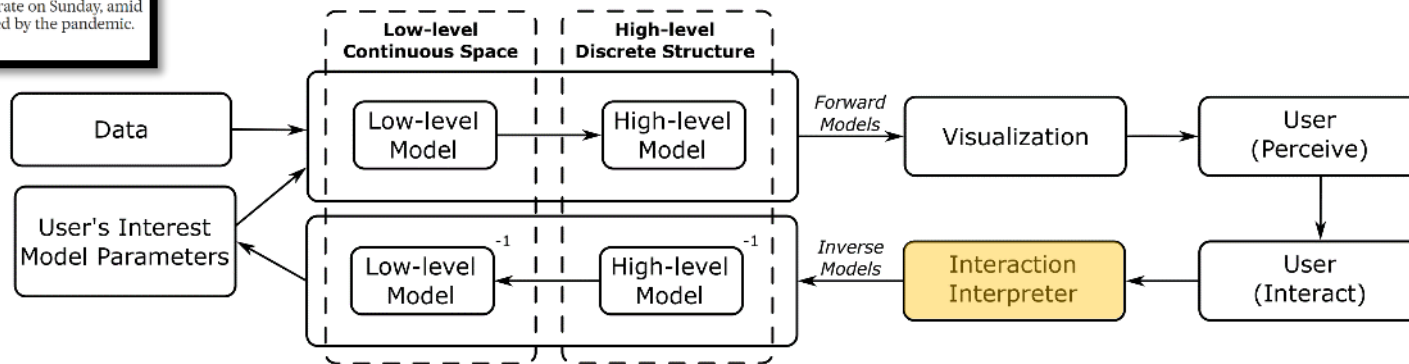
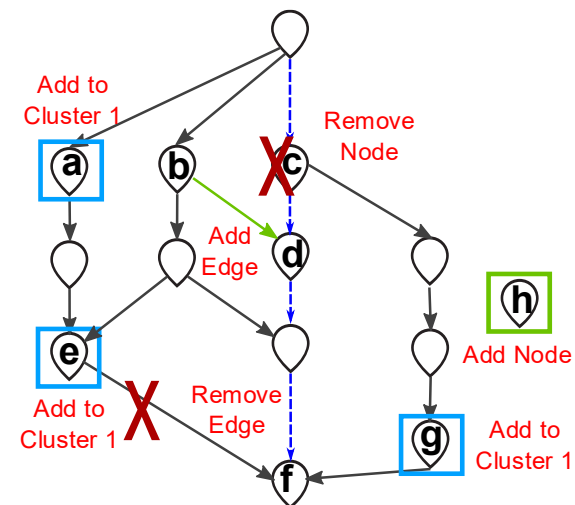

- ### User Interactions
- Grouping Events
 - Remove Event
 - Remove Connection
 - Add Event
 - Add Connection



USA **EL PAIS**

Cuba sees one of the biggest protests against the government since the crisis of the 1990s

Thousands of people all over the country came out to demonstrate on Sunday, amid a situation of shortages and hardships that has been exacerbated by the pandemic. More than a hundred arrests were made

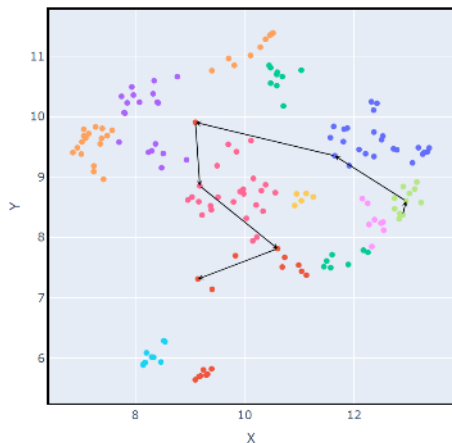

$$\begin{aligned} \max \quad & \text{minedge} - \lambda \cdot \sum_{i,j} \text{edge}_{i,j} \\ \text{s.t.} \quad & \text{minedge} \leq 1 - \text{edge}_{i,j} + \text{coherence}_{i,j} \quad \forall_{i,j} \quad [\text{Objective}] \\ & \text{node}_k = 1 \quad [\text{Fixed Start}] \\ & \text{node}_i = 0 \quad \forall_{i < s} \quad [\text{No Previous Starts}] \\ & \text{edge}_{i,j} = 0 \quad \forall_{i \geq j} \quad [\text{Chronological Order}] \\ & \sum_i \text{node}_i = K \quad [\text{Map Size}] \\ & \sum_{i < j} \text{edge}_{i,j} = \text{node}_j \quad \forall_{j \neq s} \quad [\text{Incoming Edges}] \\ & \sum_{j > i} \text{edge}_{i,j} \leq \text{node}_i \quad \forall_i \quad [\text{Outgoing Edges}] \\ \text{mincover} \leq & \frac{1}{|C|} \cdot \sum_{k \in C} \sum_{i,j} \text{edge}_{i,j} \cdot \text{membership}_{i,j,k} \quad [\text{Coverage}] \end{aligned}$$

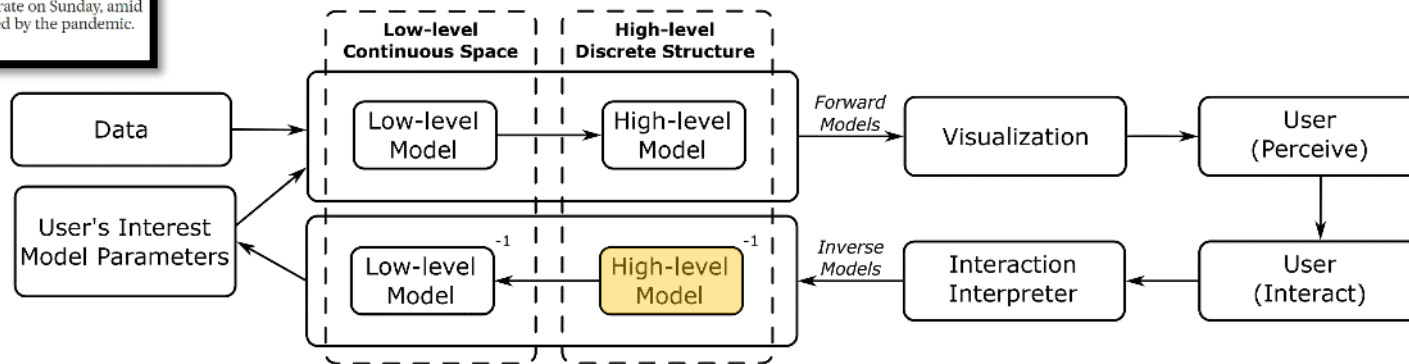
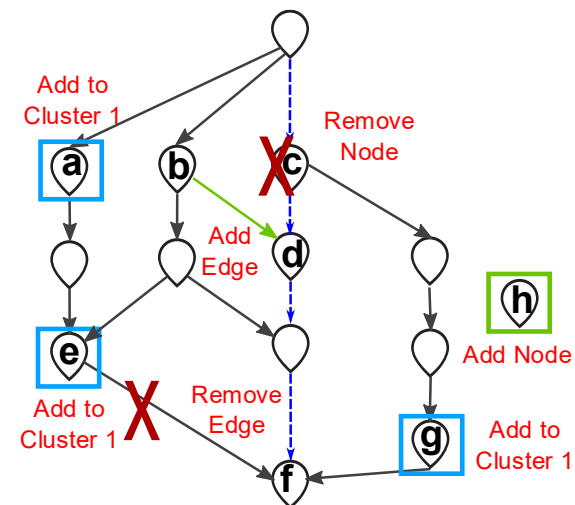

User Interactions

- Grouping Events
- Remove Event
- Remove Connection
- Add Event
- Add Connection

Clustering Constraints

For each user-defined cluster C :

For each node i in C :

Add constraint:

$$\sum_{j > i, j \in C} \text{edge}_{i,j} \geq \epsilon$$



USA **EL PAIS**

Cuba sees one of the biggest protests against the government since the crisis of the 1990s

Thousands of people all over the country came out to demonstrate on Sunday, amid a situation of shortages and hardships that has been exacerbated by the pandemic. More than a hundred arrests were made.

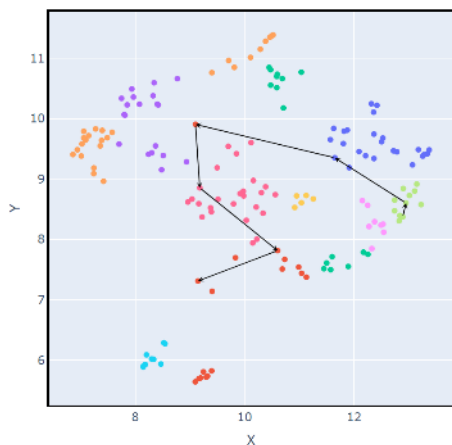

$$\begin{aligned} \max \quad & \text{minedge} - \lambda \cdot \sum_{i,j} \text{edge}_{i,j} \\ \text{s.t.} \quad & \text{minedge} \leq 1 - \text{edge}_{i,j} + \text{coherence}_{i,j} \quad \forall_{i,j} \quad [\text{Objective}] \\ & \text{node}_k = 1 \quad [\text{Fixed Start}] \\ & \text{node}_i = 0 \quad \forall_{i < s} \quad [\text{No Previous Starts}] \\ & \text{edge}_{i,j} = 0 \quad \forall_{i \geq j} \quad [\text{Chronological Order}] \\ & \sum_i \text{node}_i = K \quad [\text{Map Size}] \\ & \sum_{i < j} \text{edge}_{i,j} = \text{node}_j \quad \forall_{j \neq s} \quad [\text{Incoming Edges}] \\ & \sum_{j > i} \text{edge}_{i,j} \leq \text{node}_i \quad \forall_i \quad [\text{Outgoing Edges}] \\ \text{mincover} \leq & \frac{1}{|C|} \cdot \sum_{k \in C} \sum_{i,j} \text{edge}_{i,j} \cdot \text{membership}_{i,j,k} \quad [\text{Coverage}] \end{aligned}$$

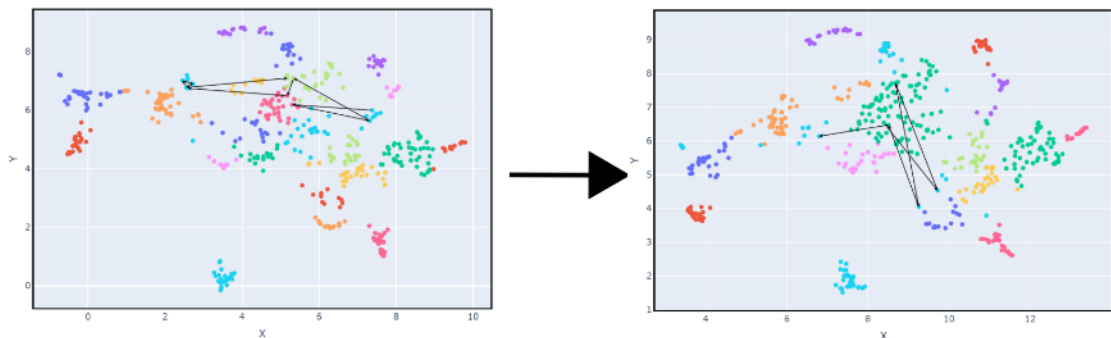
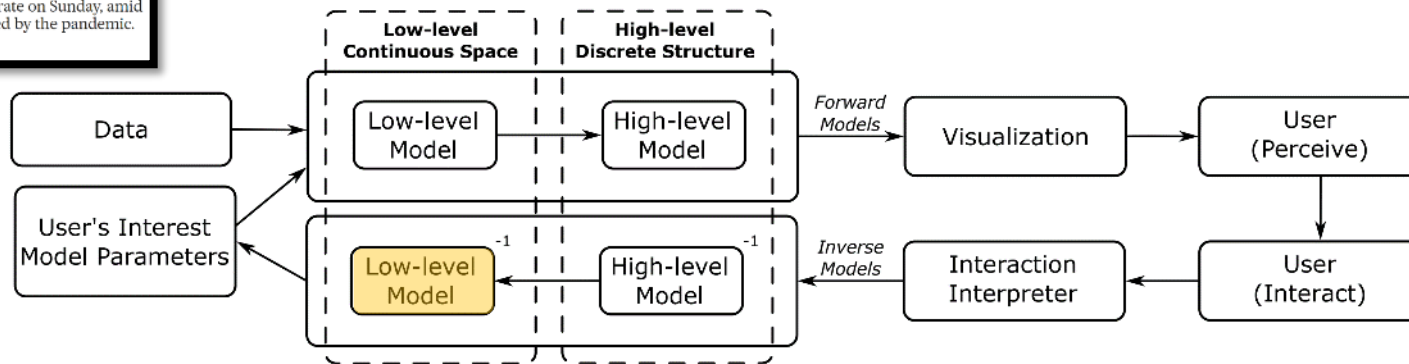
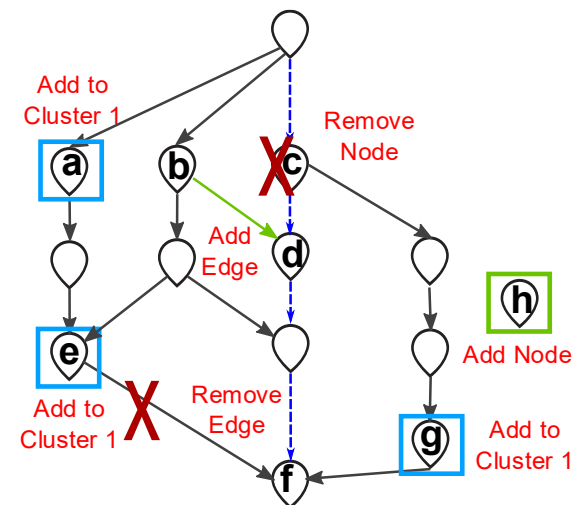

Clustering Constraints

For each user-defined cluster C :

For each node i in C :

Add constraint:

$$\sum_{j > i, j \in C} \text{edge}_{i,j} \geq \epsilon$$

User Interactions

- Grouping Events
- Remove Event
- Remove Connection
- Add Event
- Add Connection



USA **EL PAIS**

Cuba sees one of the biggest protests against the government since the crisis of the 1990s

Thousands of people all over the country came out to demonstrate on Sunday, amid a situation of shortages and hardships that has been exacerbated by the pandemic. More than a hundred arrests were made

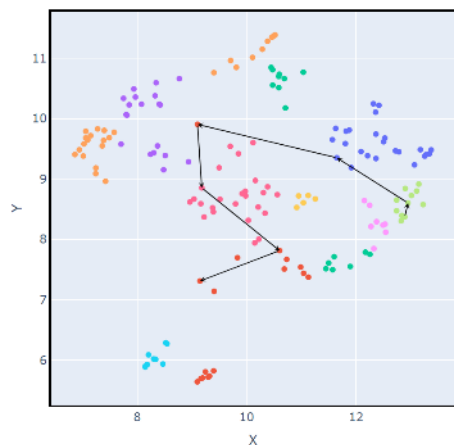

$$\begin{aligned} \max \quad & \text{minedge} - \lambda \cdot \sum_{i,j} \text{edge}_{i,j} \\ \text{s.t.} \quad & \text{minedge} \leq 1 - \text{edge}_{i,j} + \text{coherence}_{i,j} \quad \forall_{i,j} \quad [\text{Objective}] \\ & \text{node}_k = 1 \quad [\text{Fixed Start}] \\ & \text{node}_i = 0 \quad \forall_{i < k} \quad [\text{No Previous Starts}] \\ & \text{edge}_{i,j} = 0 \quad \forall_{i \geq j} \quad [\text{Chronological Order}] \\ & \sum_i \text{node}_i = K \quad [\text{Map Size}] \\ & \sum_{i < j} \text{edge}_{i,j} = \text{node}_j \quad \forall_{j \neq s} \quad [\text{Incoming Edges}] \\ & \sum_{j > i} \text{edge}_{i,j} \leq \text{node}_i \quad \forall_i \quad [\text{Outgoing Edges}] \\ \text{mincover} \leq & \frac{1}{|C|} \cdot \sum_{k \in C} \sum_{i,j} \text{edge}_{i,j} \cdot \text{membership}_{i,j,k} \quad [\text{Coverage}] \end{aligned}$$

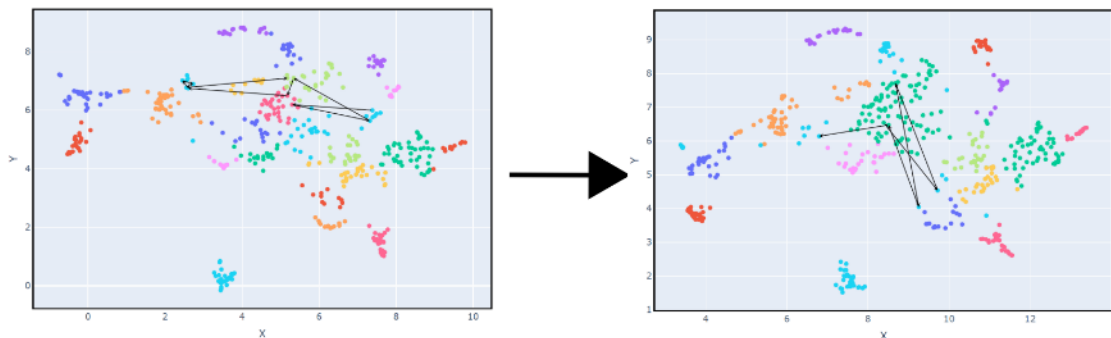
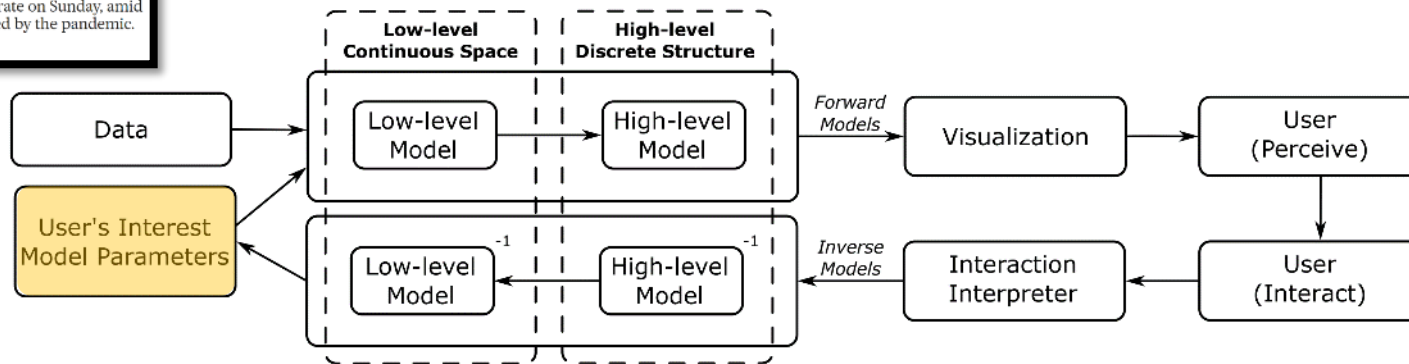
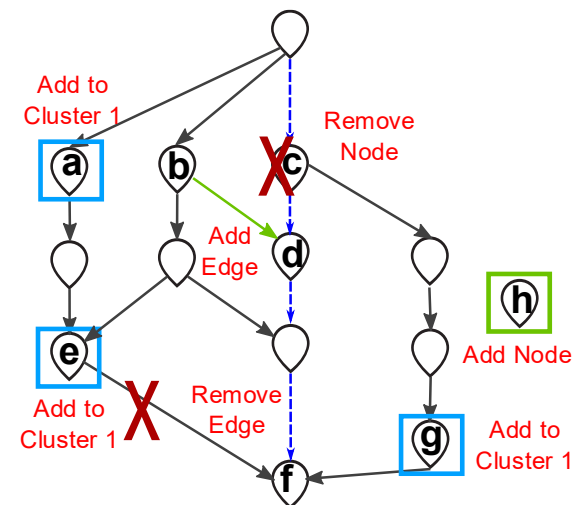

Clustering Constraints

For each user-defined cluster C :

For each node i in C :

Add constraint:

$$\sum_{j > i, j \in C} \text{edge}_{i,j} \geq \epsilon$$

User Interactions

- Grouping Events
- Remove Event
- Remove Connection
- Add Event
- Add Connection



USA **EL PAIS**

Cuba sees one of the biggest protests against the government since the crisis of the 1990s

Thousands of people all over the country came out to demonstrate on Sunday, amid a situation of shortages and hardships that has been exacerbated by the pandemic. More than a hundred arrests were made

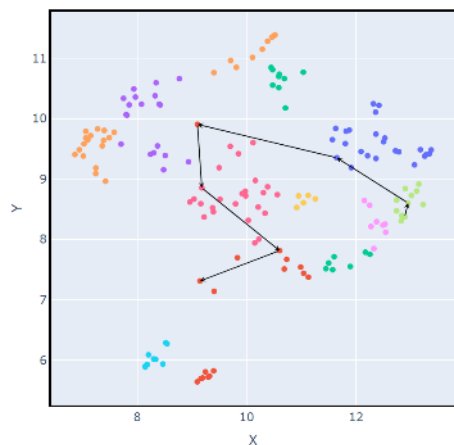

$$\begin{aligned} \max \quad & \text{minedge} - \lambda \cdot \sum_{i,j} \text{edge}_{i,j} \\ \text{s.t.} \quad & \text{minedge} \leq 1 - \text{edge}_{i,j} + \text{coherence}_{i,j} \quad \forall_{i,j} \quad [\text{Objective}] \\ & \text{node}_k = 1 \quad [\text{Fixed Start}] \\ & \text{node}_i = 0 \quad \forall_{i < k} \quad [\text{No Previous Starts}] \\ & \text{edge}_{i,j} = 0 \quad \forall_{i \geq j} \quad [\text{Chronological Order}] \\ & \sum_i \text{node}_i = K \quad [\text{Map Size}] \\ & \sum_{i < j} \text{edge}_{i,j} = \text{node}_j \quad \forall_{j \neq s} \quad [\text{Incoming Edges}] \\ & \sum_{j > i} \text{edge}_{i,j} \leq \text{node}_i \quad \forall_i \quad [\text{Outgoing Edges}] \\ \text{mincover} \leq & \frac{1}{|C|} \cdot \sum_{k \in C} \sum_{i,j} \text{edge}_{i,j} \cdot \text{membership}_{i,j,k} \quad [\text{Coverage}] \end{aligned}$$

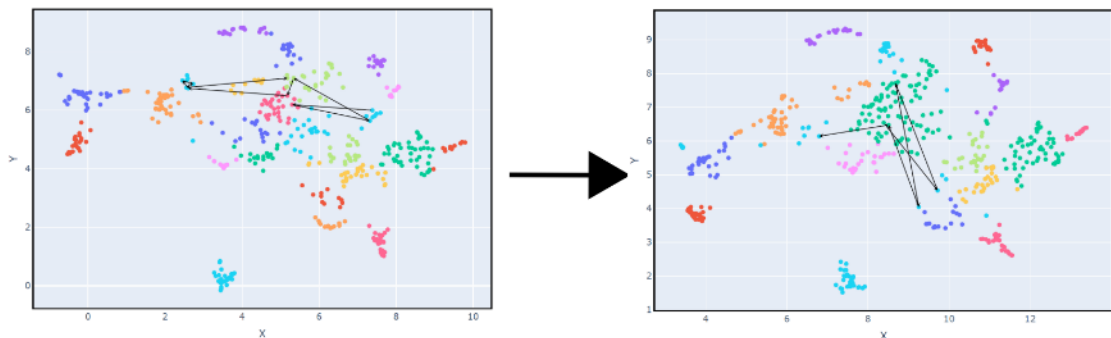
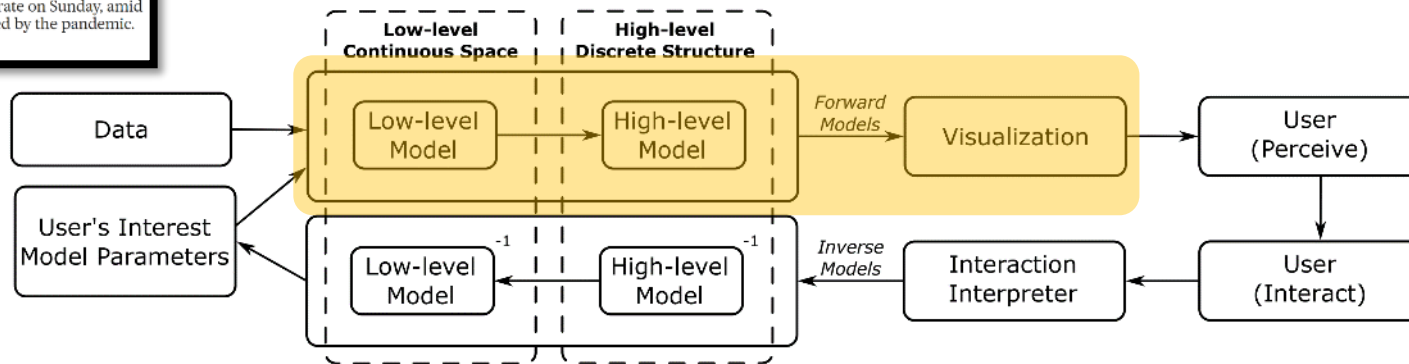
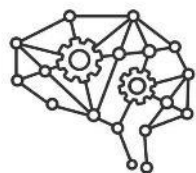
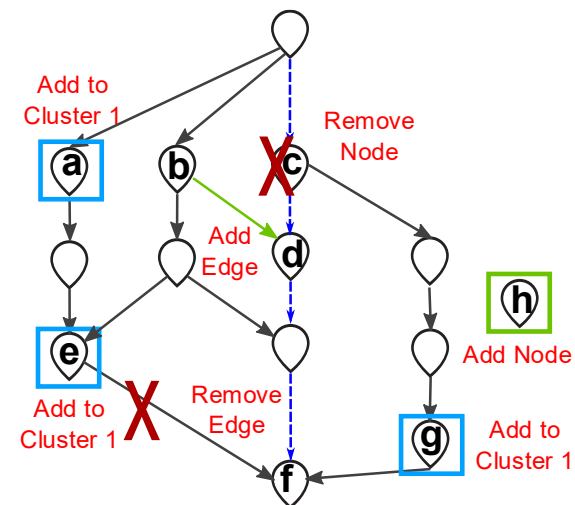

Clustering Constraints

For each user-defined cluster C :

For each node i in C :

Add constraint:

$$\sum_{j > i, j \in C} \text{edge}_{i,j} \geq \epsilon$$

User Interactions

- Grouping Events
- Remove Event
- Remove Connection
- Add Event
- Add Connection



USA **EL PAIS**

Cuba sees one of the biggest protests against the government since the crisis of the 1990s

Thousands of people all over the country came out to demonstrate on Sunday, amid a situation of shortages and hardships that has been exacerbated by the pandemic. More than a hundred arrests were made

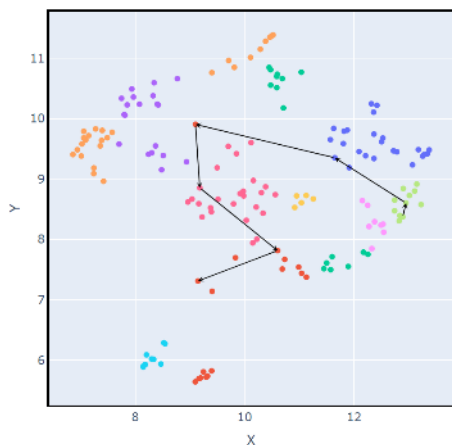

$$\begin{aligned} \max \quad & \text{minedge} - \lambda \cdot \sum_{i,j} \text{edge}_{i,j} \\ \text{s.t.} \quad & \text{minedge} \leq 1 - \text{edge}_{i,j} + \text{coherence}_{i,j} \quad \forall_{i,j} \quad [\text{Objective}] \\ & \text{node}_k = 1 \quad [\text{Fixed Start}] \\ & \text{node}_i = 0 \quad \forall_{i < k} \quad [\text{No Previous Starts}] \\ & \text{edge}_{i,j} = 0 \quad \forall_{i \geq j} \quad [\text{Chronological Order}] \\ & \sum_i \text{node}_i = K \quad [\text{Map Size}] \\ & \sum_{i < j} \text{edge}_{i,j} = \text{node}_j \quad \forall_{j \neq s} \quad [\text{Incoming Edges}] \\ & \sum_{j > i} \text{edge}_{i,j} \leq \text{node}_i \quad \forall_i \quad [\text{Outgoing Edges}] \\ \text{mincover} \leq & \frac{1}{|C|} \cdot \sum_{k \in C} \sum_{i,j} \text{edge}_{i,j} \cdot \text{membership}_{i,j,k} \quad [\text{Coverage}] \end{aligned}$$

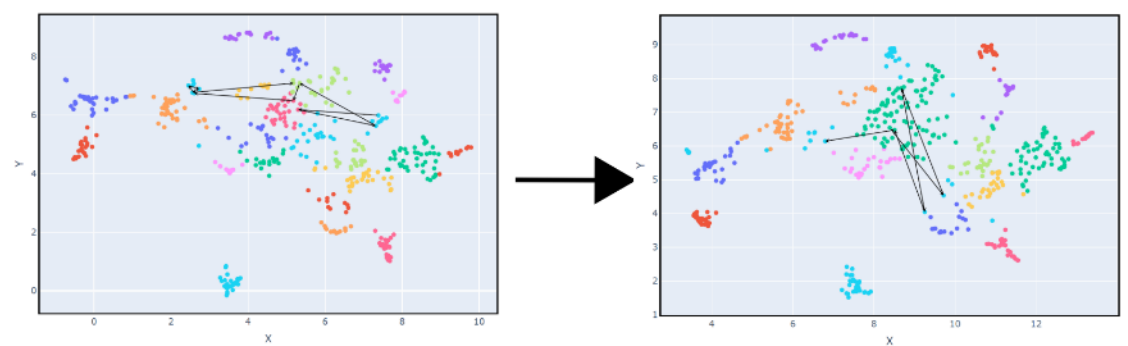
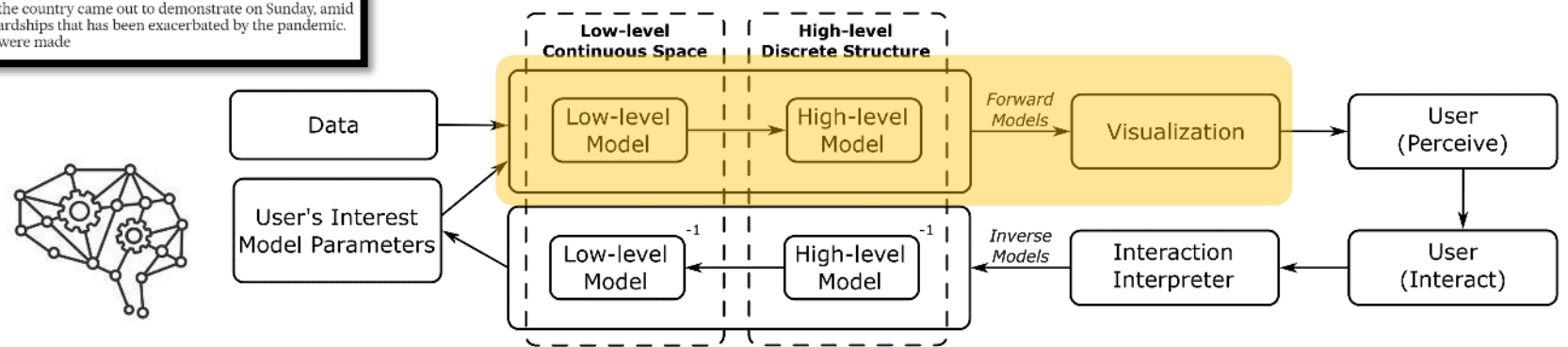
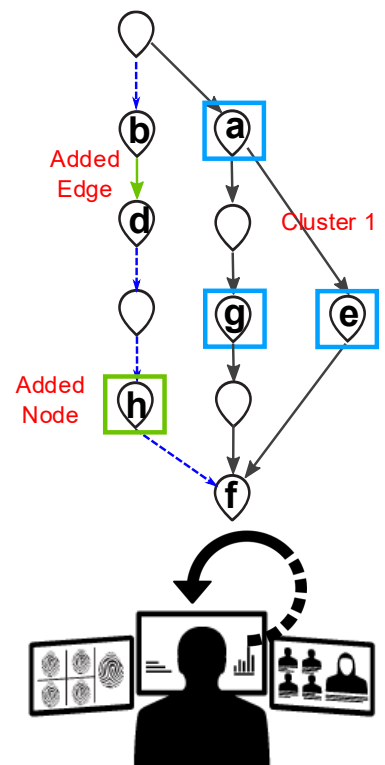

Clustering Constraints

For each user-defined cluster C :

For each node i in C :

Add constraint:

$$\sum_{j > i, j \in C} \text{edge}_{i,j} \geq \epsilon$$

User Interactions

- Grouping Events
- Remove Event
- Remove Connection
- Add Event
- Add Connection

User Study: Insight-based Evaluation

Interactive AI Evaluation

How effective is our interactive AI model at aiding analysts in sensemaking tasks?

- Insight-based evaluation methodology.
- 2021 Cuban Protests news data set.
- Evaluation questionnaires.
- Post-task unstructured interview and general feedback.

Experimental Design

- 36 participants.
- 15 minutes of training time.
- 1 hour to complete task.

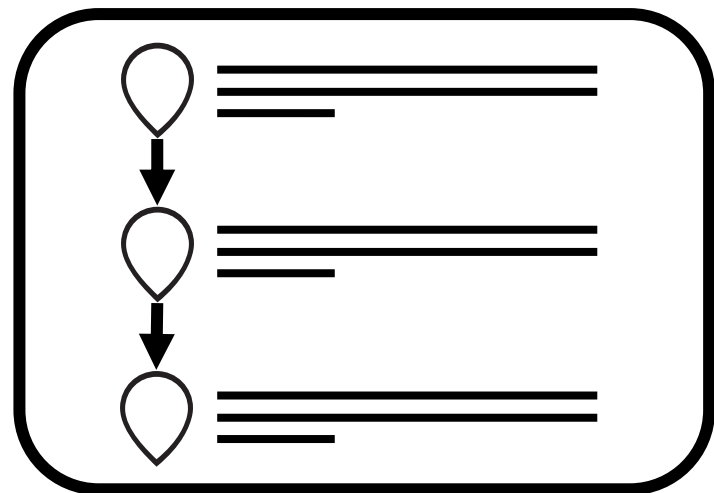

Timeline with
Search

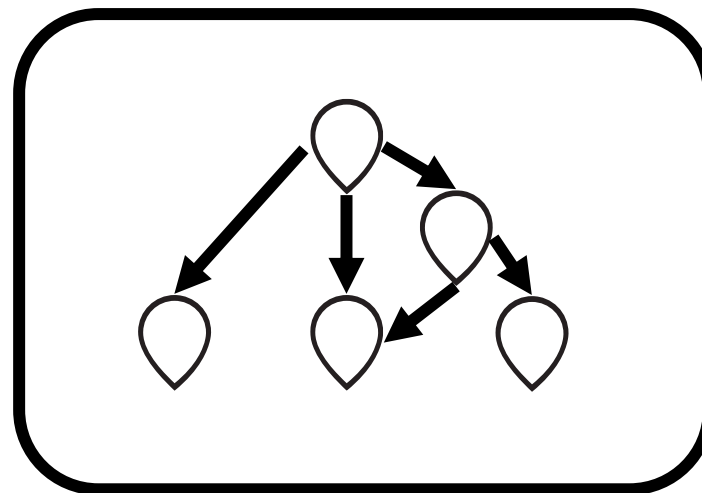

Basic Narrative
Maps

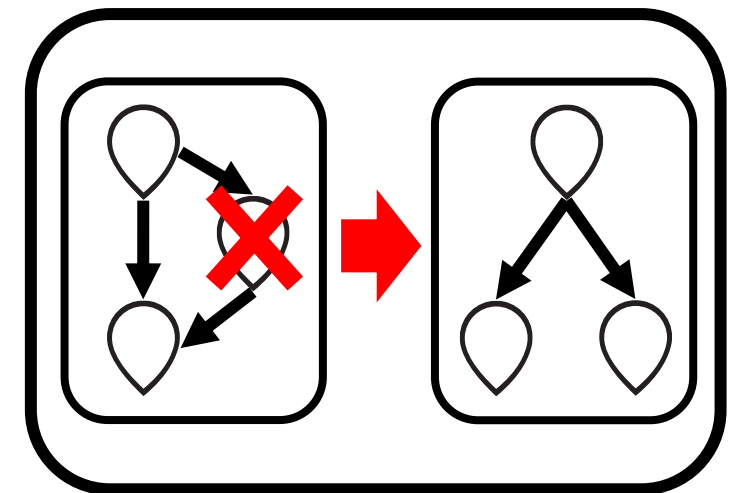

Narrative Maps +
Semantic Interaction

Insight Coding

- We used open coding to analyze and categorize all insights.
- Low-level insights vs. high-level insights.

Insights	S1	S2	S3	S4	S5	S6	S7	S8	S9	S10	B1	B2	B3	B4	B5	B6	B7	B8	B9	B11	B12	B13	B14	I1	I2	I3	I4	I6	I7	I8	I9	I10	I11		
Causes: Economic Crisis	x	x	x	x	x	x	x	x	x	x		x	x	x	x	x	x	x	x	x	x	x	x	x	x	x	x	x	x	x	x	x	x		
Worst economic crisis since fall of Soviet Union / 30 years								x				x		x																					
Basic necessities and food shortages	x	x	x		x	x	x	x	x	x		x	x	x	x	x	x	x	x	x	x	x	x	x	x	x	x	x	x	x	x	x	x	x	
Medicine and hygiene products shortages			x		x				x	x		x	x	x	x	x	x	x			x	x	x								x	x			
People turning to black market / alternative sources				x												x																			
High / rising prices, job shortages, inability to support businesses	x	x	x	x		x						x	x		x	x				x		x	x	x				x						x	
Power outages and unstable utilities		x	x	x			x	x	x					x	x					x	x	x										x	x		
Internet outages				x					x	x										x	x	x													x
Lack of flights available out of the country				x																						x									

Insight Coding

Insights	S1	S2	S3	S4	S5	S6	S7	S8	S9	S10	B1	B2	B3	B4	B5	B6	B7	B8	B9	B11	B12	B13	B14	I1	I2	I3	I4	I6	I7	I8	I9	I10	I11	
Causes: Economic Crisis	x	x	x	x	x	x	x	x	x	x	x	x	x	x	x	x	x	x	x	x	x	x	x	x	x	x	x	x	x	x	x	x	x	
Worst economic crisis since fall of Soviet Union / 30 years																																		
Basic necessities and food shortages	x	x	x	x	x	x	x	x	x	x	x	x	x	x	x	x	x	x	x	x	x	x	x	x	x	x	x	x	x	x	x	x	x	
Medicine and hygiene products shortages	x	x	x	x	x	x	x	x	x	x	x	x	x	x	x	x	x	x	x	x	x	x	x	x	x	x	x	x	x	x	x	x	x	
People turning to black market / alternative sources																																		
High / rising prices, job shortages, inability to support businesses	x	x	x	x	x	x	x	x	x	x	x	x	x	x	x	x	x	x	x	x	x	x	x	x	x	x	x	x	x	x	x	x	x	
Power outages and unstable utilities	x	x	x	x	x	x	x	x	x	x	x	x	x	x	x	x	x	x	x	x	x	x	x	x	x	x	x	x	x	x	x	x	x	
Internet outages																																		
Lack of flights available out of the country																																		
Causes: Underlying Economic Issues	x	x	x	x	x	x	x	x	x	x	x	x	x	x	x	x	x	x	x	x	x	x	x	x	x	x	x	x	x	x	x	x	x	
Economic crisis and shortages worsened by the COVID-19 pandemic	x	x	x	x	x	x	x	x	x	x	x	x	x	x	x	x	x	x	x	x	x	x	x	x	x	x	x	x	x	x	x	x	x	
Tourism industry impacted by COVID-19	x	x	x	x	x	x	x	x	x	x	x	x	x	x	x	x	x	x	x	x	x	x	x	x	x	x	x	x	x	x	x	x	x	
Trade / exports impacted by COVID-19																																		
Economic crisis worsened by Cuban policies / mishandling of spending	x	x	x	x	x	x	x	x	x	x	x	x	x	x	x	x	x	x	x	x	x	x	x	x	x	x	x	x	x	x	x	x	x	
Restrictions on food and medicine imports / customs fees																																		
General inefficiencies due to communist economy / Soviet-style system																																		
Causes: Healthcare Crisis	x	x	x	x	x	x	x	x	x	x	x	x	x	x	x	x	x	x	x	x	x	x	x	x	x	x	x	x	x	x	x	x	x	
Ongoing pandemic / general effects of COVID-19 in the healthcare system	x	x	x	x	x	x	x	x	x	x	x	x	x	x	x	x	x	x	x	x	x	x	x	x	x	x	x	x	x	x	x	x	x	
Government mishandling of the COVID-19 pandemic	x	x	x	x	x	x	x	x	x	x	x	x	x	x	x	x	x	x	x	x	x	x	x	x	x	x	x	x	x	x	x	x	x	
Cuba's universal / government-controlled healthcare system issues																																		
Recent surge in COVID-19 cases	x	x	x	x	x	x	x	x	x	x	x	x	x	x	x	x	x	x	x	x	x	x	x	x	x	x	x	x	x	x	x	x	x	
Lack of access to vaccines / vaccination pace																																		
Food scarcity is compounding healthcare issues																																		
Cuban officials blaming / suppressing overworked doctors																																		
Causes: Ongoing Violence	x	x	x	x	x	x	x	x	x	x	x	x	x	x	x	x	x	x	x	x	x	x	x	x	x	x	x	x	x	x	x	x	x	
Government violence and repression	x	x	x	x	x	x	x	x	x	x	x	x	x	x	x	x	x	x	x	x	x	x	x	x	x	x	x	x	x	x	x	x	x	
Public riots / gang beatings																																		
Human rights abuses																																		
Religious persecution																																		
Causes: U.S. Sanctions	x	x	x	x	x	x	x	x	x	x	x	x	x	x	x	x	x	x	x	x	x	x	x	x	x	x	x	x	x	x	x	x	x	
Pre-existing sanctions / embargo	x	x	x	x	x	x	x	x	x	x	x	x	x	x	x	x	x	x	x	x	x	x	x	x	x	x	x	x	x	x	x	x	x	
Long-standing history between U.S. and Cuba	x	x	x	x	x	x	x	x	x	x	x	x	x	x	x	x	x	x	x	x	x	x	x	x	x	x	x	x	x	x	x	x	x	
Recently increased sanctions	x	x	x	x	x	x	x	x	x	x	x	x	x	x	x	x	x	x	x	x	x	x	x	x	x	x	x	x	x	x	x	x	x	
Trump period sanctions	x	x	x	x	x	x	x	x	x	x	x	x	x	x	x	x	x	x	x	x	x	x	x	x	x	x	x	x	x	x	x	x	x	
Obama's easing and Trump's reversal																																		
Causes: Political Discontent	x	x	x	x	x	x	x	x	x	x	x	x	x	x	x	x	x	x	x	x	x	x	x	x	x	x	x	x	x	x	x	x	x	
Protests about general government shortcomings	x	x	x	x	x	x	x	x	x	x	x	x	x	x	x	x	x	x	x	x	x	x	x	x	x	x	x	x	x	x	x	x	x	
Long-standing communist regime / six decades	x	x	x	x	x	x	x	x	x	x	x	x	x	x	x	x	x	x	x	x	x	x	x	x	x	x	x	x	x	x	x	x	x	
Protesters want the End of the Dictatorship / Change Communist Regime / Democracy	x	x	x	x	x	x	x	x	x	x	x	x	x	x	x	x	x	x	x	x	x	x	x	x	x	x	x	x	x	x	x	x	x	
Lack of freedoms / civil liberties (in general, speech, etc)																																		
Political turmoil after Castro stepping down																																		
Government's direct control and responsibility on state-run services (food and medical)																																		
Causes: Social Media and Internet Access	x	x	x	x	x	x	x	x	x	x	x	x	x	x	x	x	x	x	x	x	x	x	x	x	x	x	x	x	x	x	x	x	x	
Internet access and social media played a role in the protests	x	x	x	x	x	x	x	x	x	x	x	x	x	x	x	x	x	x	x	x	x	x	x	x	x	x	x	x	x	x	x	x	x	
Connections to Cuban diaspora and their influence																																		
Recent expansion of internet access / mobile internet / lack of access																																		
Restrictions on internet access before protests / pre-existing censorship																																		
Social media sparking protests																																		
Facebook groups sparking protests ("City of Humor")																																		
U.S. promoting instability through social media campaigns																																		

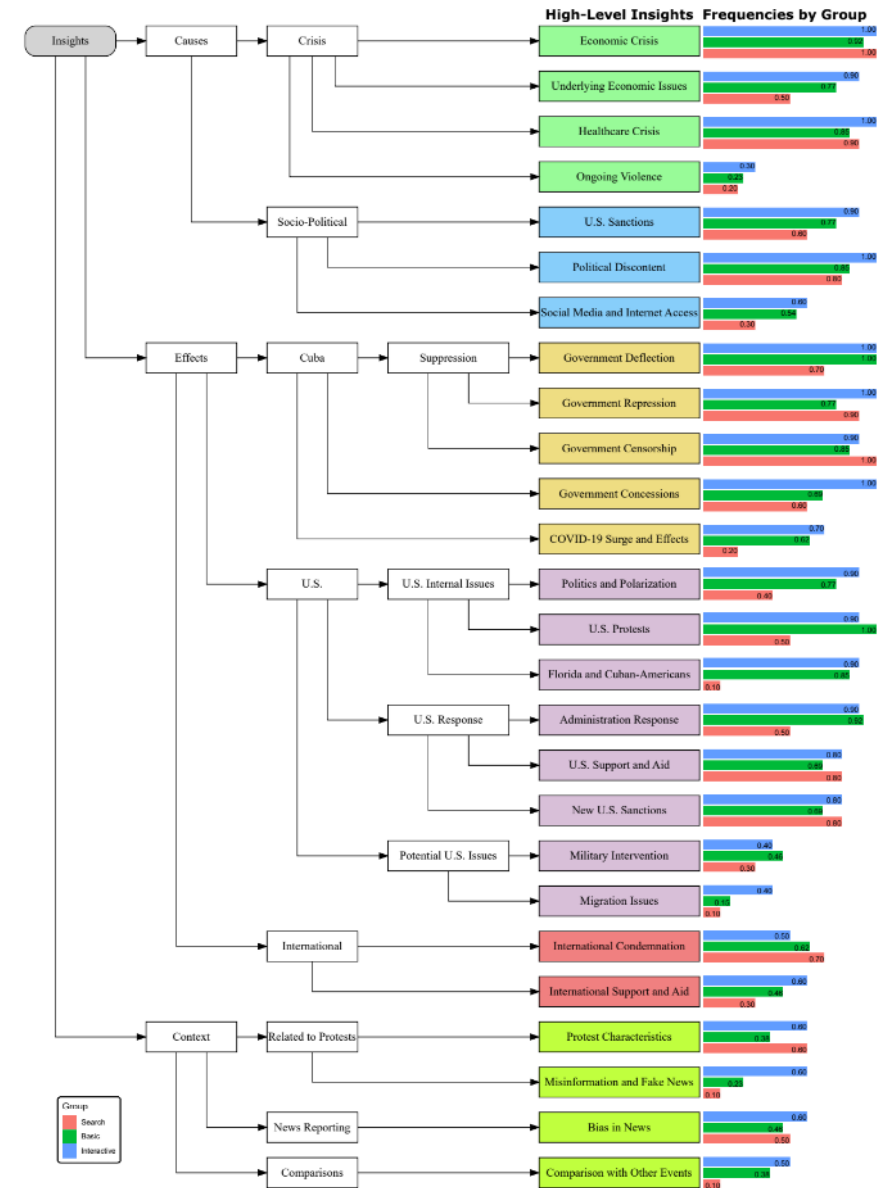

Insight Tree

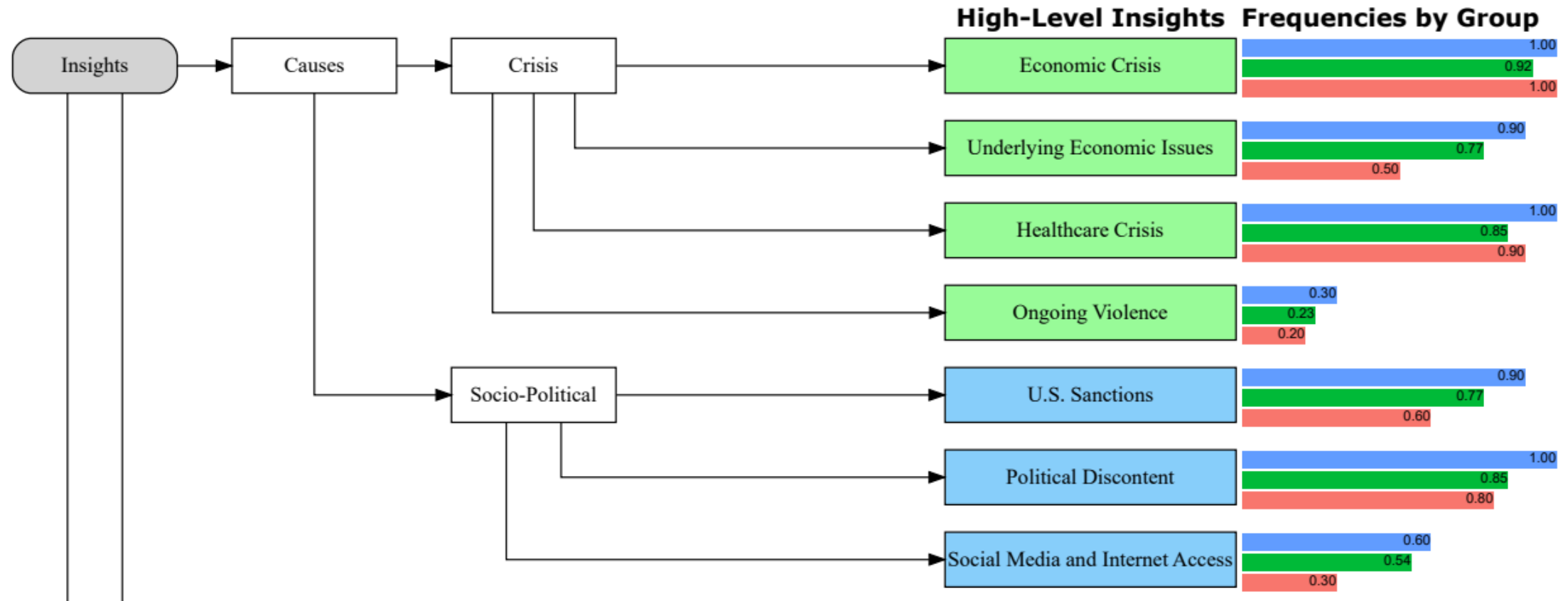

Insight Tree

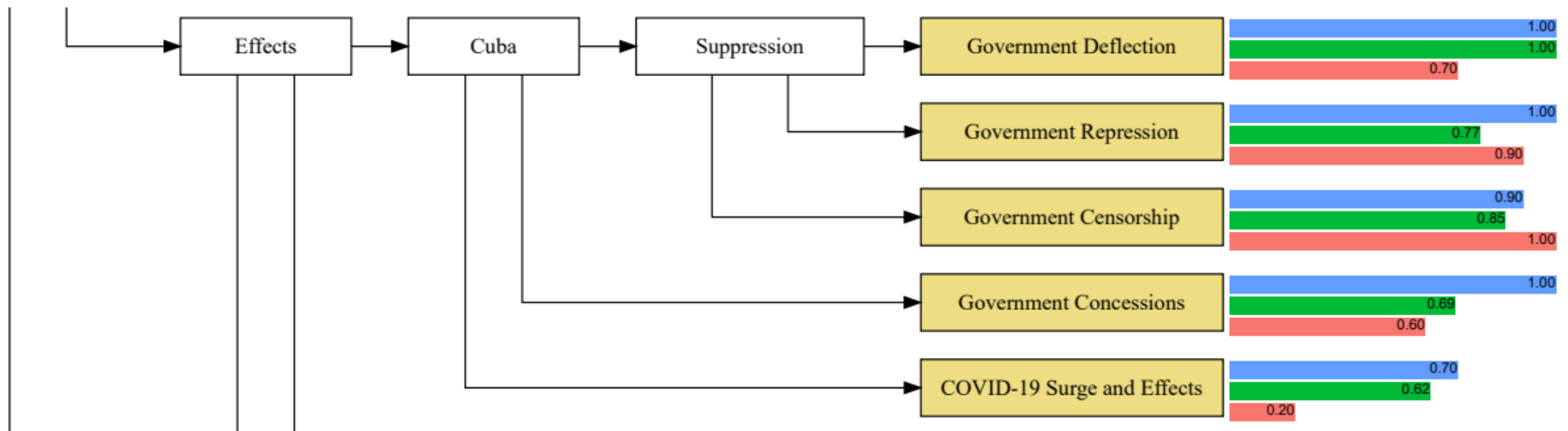

Insight Tree

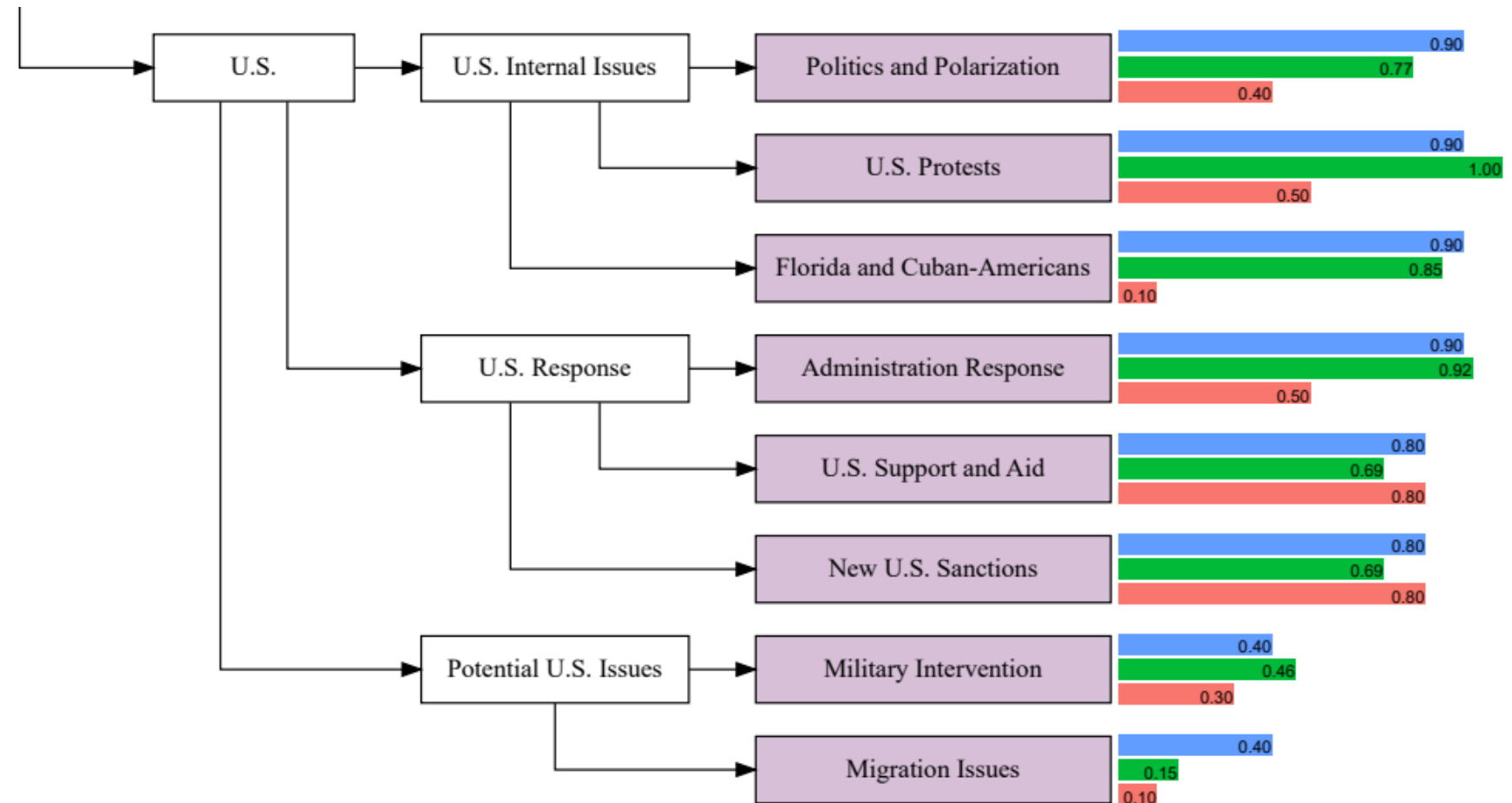

Insight Tree

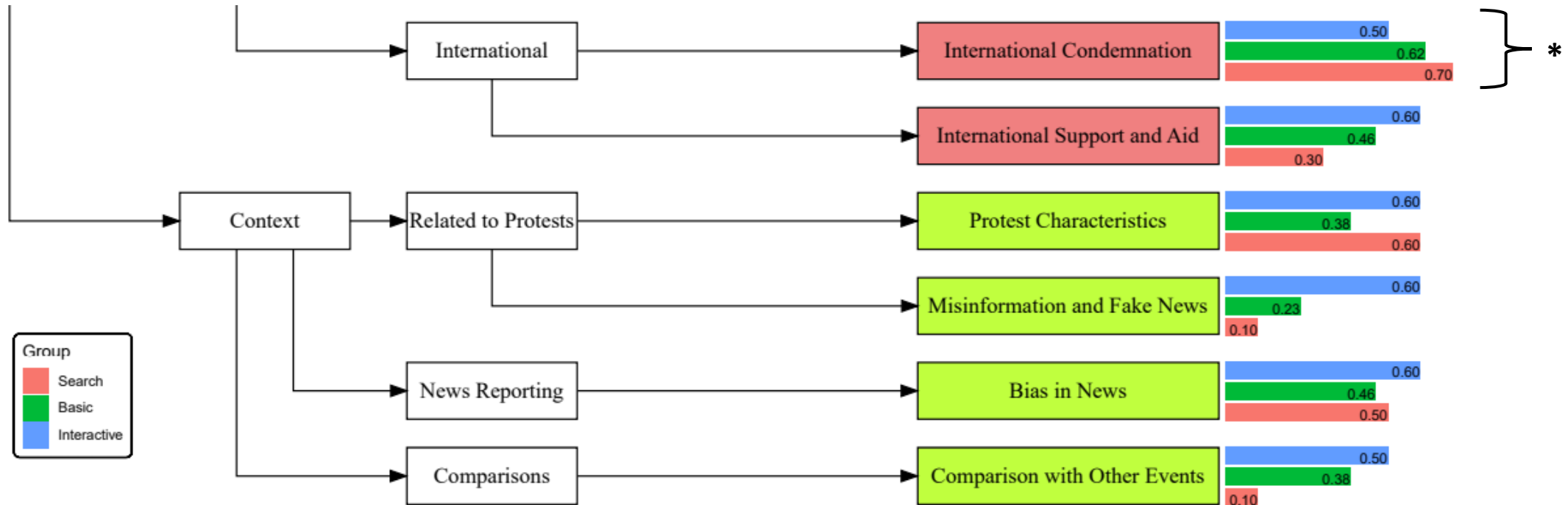

Insight Evaluation

(a) High-level Insights

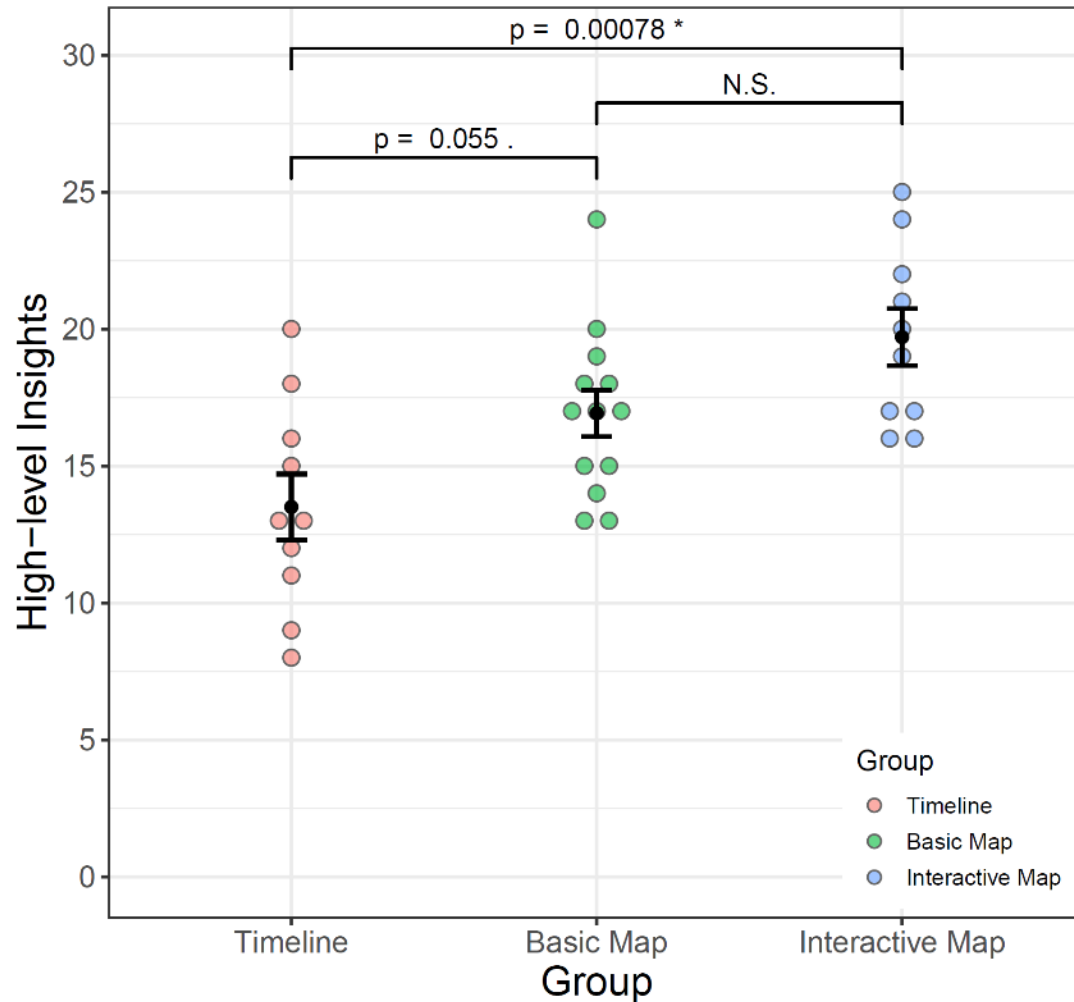

(b) Low-level Insights

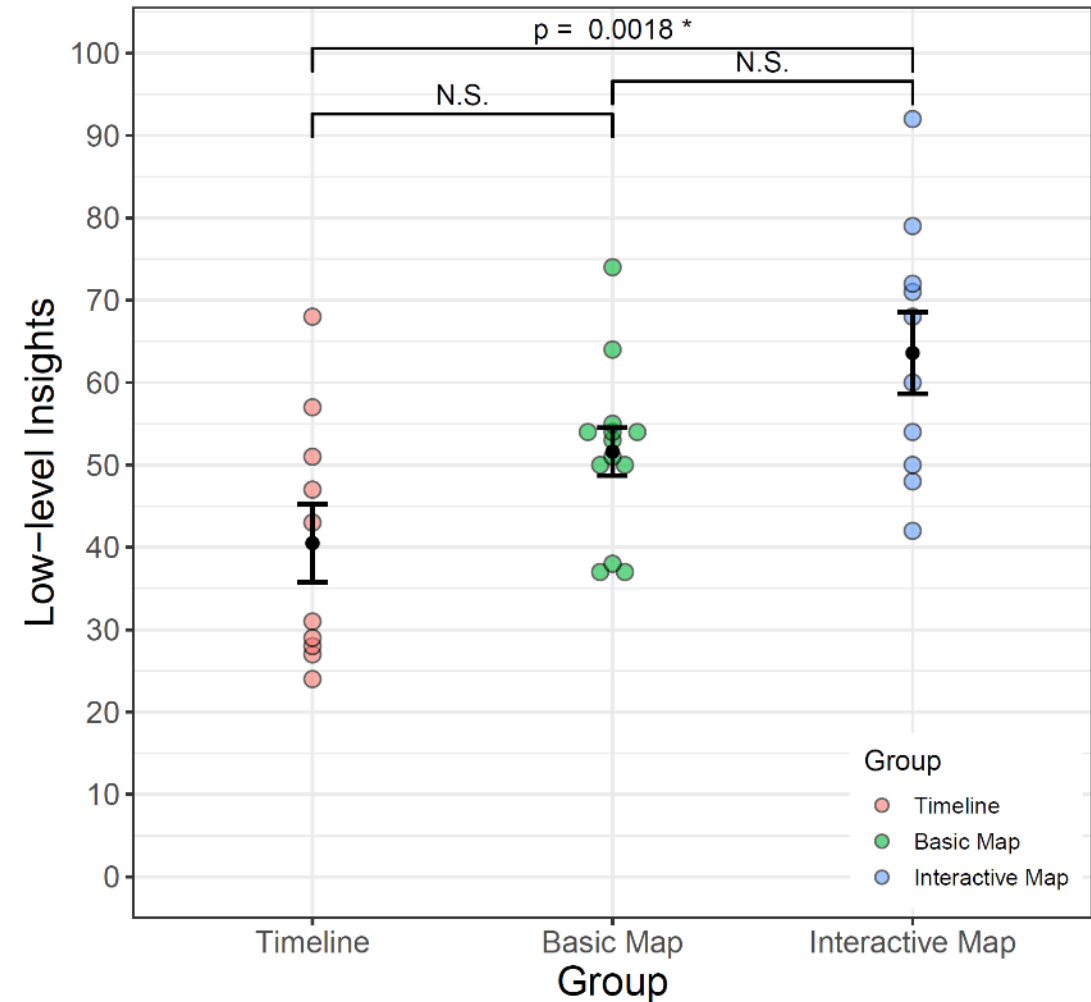

Usability Evaluation

Items	Search						Basic						Interactive					
						M						M						M
	Strongly Disagree	Disagree	Neutral	Agree	Strongly Agree		Strongly Disagree	Disagree	Neutral	Agree	Strongly Agree		Strongly Disagree	Disagree	Neutral	Agree	Strongly Agree	
	1	2	3	4	5	M	1	2	3	4	5	M	1	2	3	4	5	M
Usefulness	0	0	0	9	1	4.10	0	0	0	9	4	4.31	0	0	0	2	8	4.80
Ease of Use (*)	0	0	1	3	6	4.50	0	0	0	13	0	4.00	0	1	2	7	0	3.60
Reuse	0	0	2	5	3	4.10	0	0	2	4	7	4.38	0	0	0	1	9	4.90
Representation	0	0	2	5	3	4.10	0	0	3	8	2	3.92	0	0	0	8	2	4.20
Redundancy (*)	0	5	2	2	1	2.90	1	3	6	3	0	2.85	0	1	2	7	0	3.60
Relevance (*)	0	0	2	5	3	4.10	0	1	0	7	5	4.23	0	0	0	5	5	4.50
Depth	0	0	1	7	2	4.10	0	0	2	6	5	4.23	0	0	0	8	2	4.20

* { Usefulness, Ease of Use, Reuse, Representation, Redundancy, Relevance, Depth }
 ~ { Relevance, Depth }

Interactive AI Evaluation

		Responses					M
		Strongly Disagree	Disagree	Neutral	Agree	Strongly Agree	
		1	2	3	4	5	M
SI Items	Interaction Relevance	0	0	1	9	0	3.90
	Learning Model	0	0	0	8	2	4.20
	Usefulness	0	0	1	6	3	4.20
	Model Trust	0	0	4	4	2	3.80

Reading Behaviors

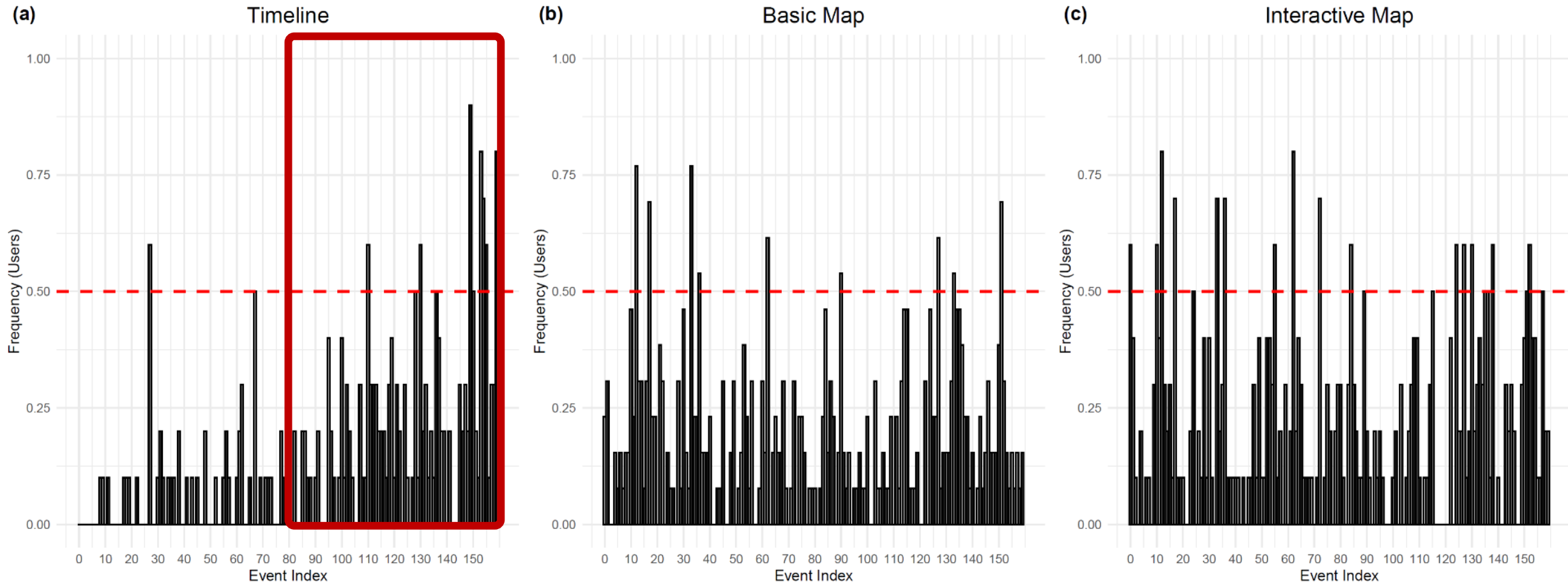

Map Usage Strategies

- Many different strategies that change over time.

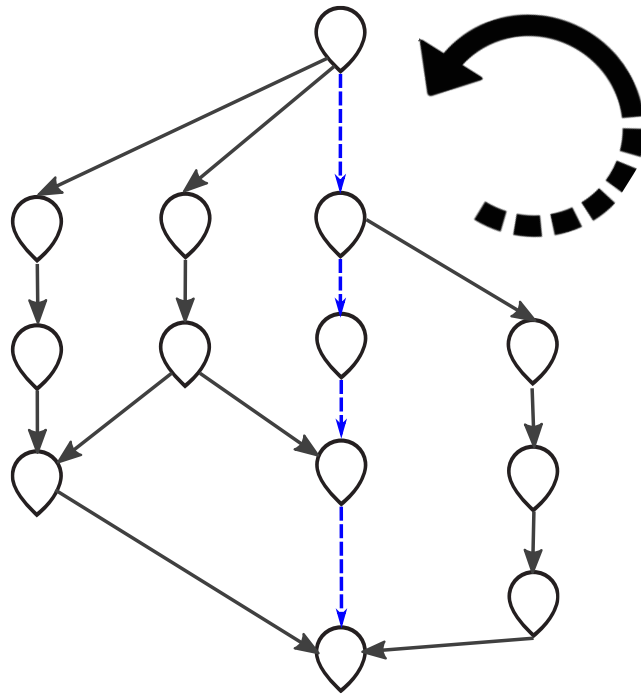

Single Map Focus

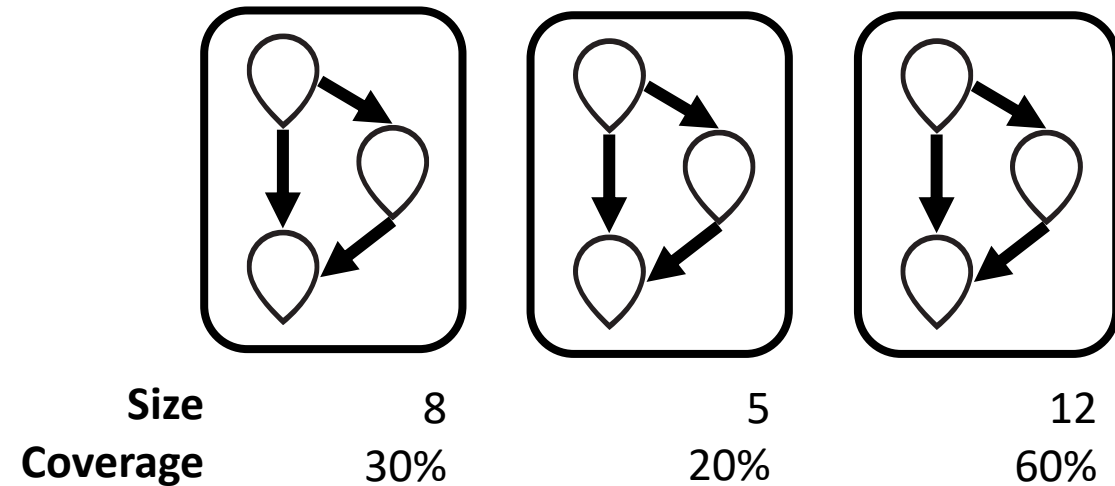

Parametric Exploration

Comprehensive Timeline

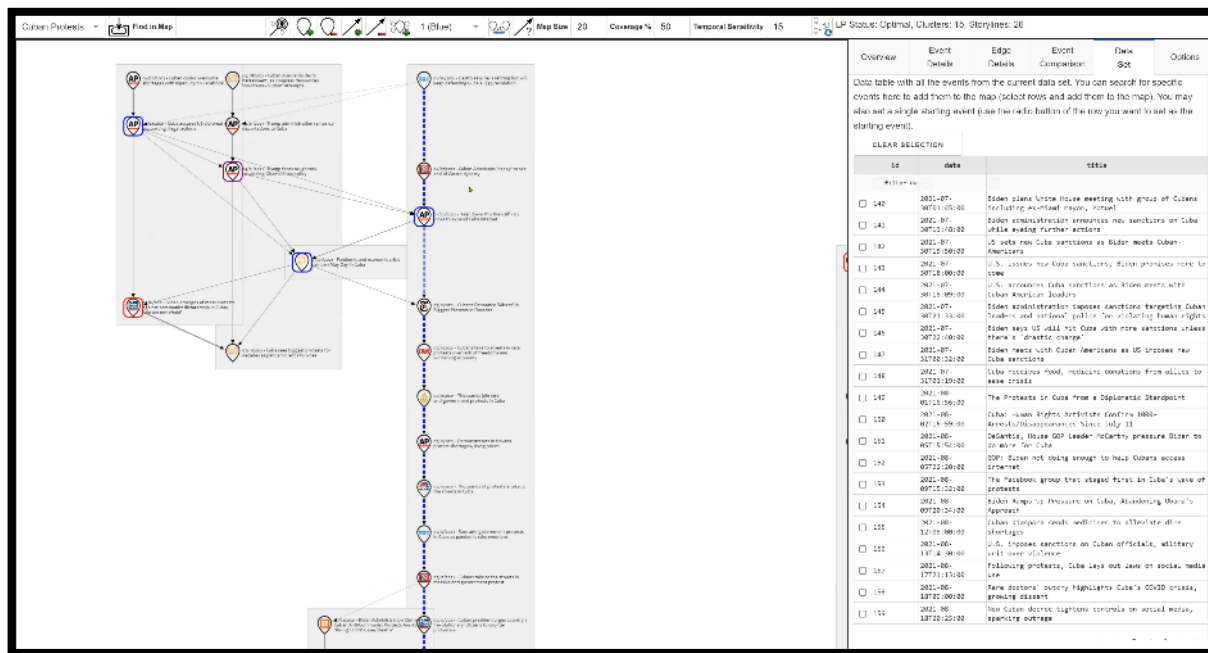
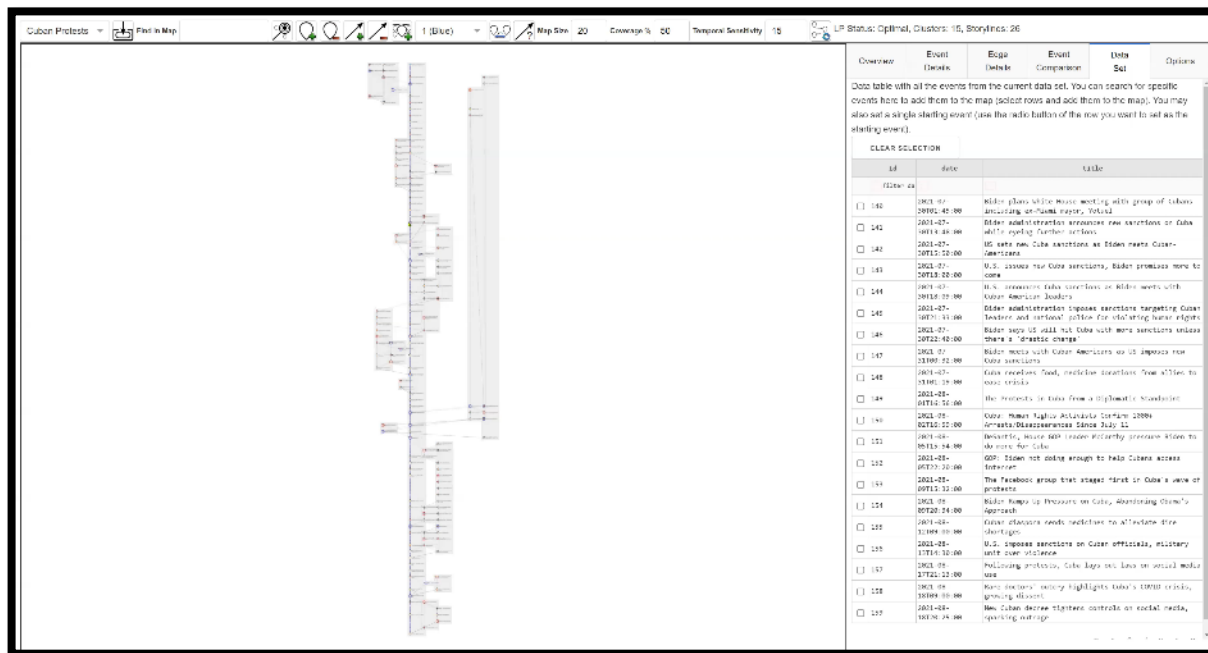
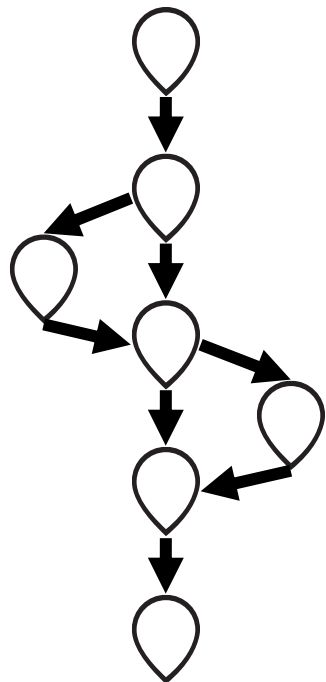

Semantic Interaction Strategies



Corrective vs Additive.

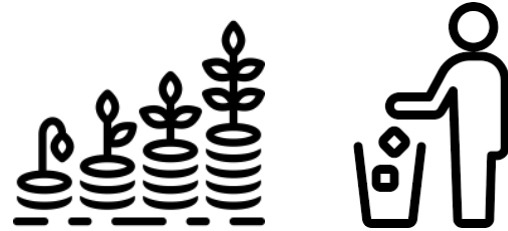

Cumulative vs Single-use.

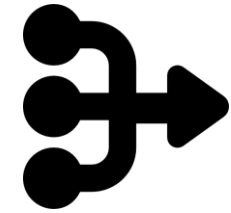

**Combining with
parametric interactions.**

Semantic Interaction Strategies

- Concrete strategy examples:

Strategy	Corrective	Additive	Parametric	Type
Removing Bias	×			Cumulative
Topical Clusters		×		Single-use
Iterative Refinement	×	×		Cumulative
Resetting and Small Clusters	×	×	×	Mixed
System as a Playground	×	×	×	Cumulative



Strategy	Corrective	Additive	Parametric	Type
Removing Bias	×			Cumulative
Topical Clusters		×		Single-use
Iterative Refinement	×	×		Cumulative
Resetting and Small Clusters	×	×	×	Mixed
System as a Playground	×	×	×	Cumulative

The screenshot displays a complex network diagram of semantic interactions. The nodes represent events, and the edges represent relationships between them. Key clusters are highlighted with boxes and labels:

- The 1 harmful practices**: Includes events like "Where's Biden's chair breaks out of Florida protest" and "Biden offers review of concessions to Cuba".
- Cuba's leader**: Includes events like "Cuba sees biggest protests for decades as pandemic adds to woes" and "Cuban government uses special units to intimidate protesters on the island".
- Rubio Slams Biden Admin's Major Failure**: Includes events like "Cuban government aggressively represses protests" and "Cuban government claims protests part of its plan to restore 'Cubanness' to the island".
- Miami's Sps Cuba protesters**: Includes events like "Hundreds of Miami's Sps Cuba protesters sing Puerto-Vida in Little Havana" and "Protesters break out to demand US Congress take firmer stance on Cuba".

On the right, an **Overview** panel provides a summary of the story: "Part of the Storyline: Obama's Cuba easing...". It lists key keywords and importance metrics for various events, such as "social media" (11.4%), "income" (10.2%), and "protests" (10.2%).

Strategy

Corrective

Additive

Parametric

Type

Removing Bias

×

Cumulative

Topical Clusters

×

×

Single-use

Iterative Refinement

×

×

Cumulative

Resetting and Small Clusters

×

×

×

Mixed

System as a Playground

×

×

×

Cumulative

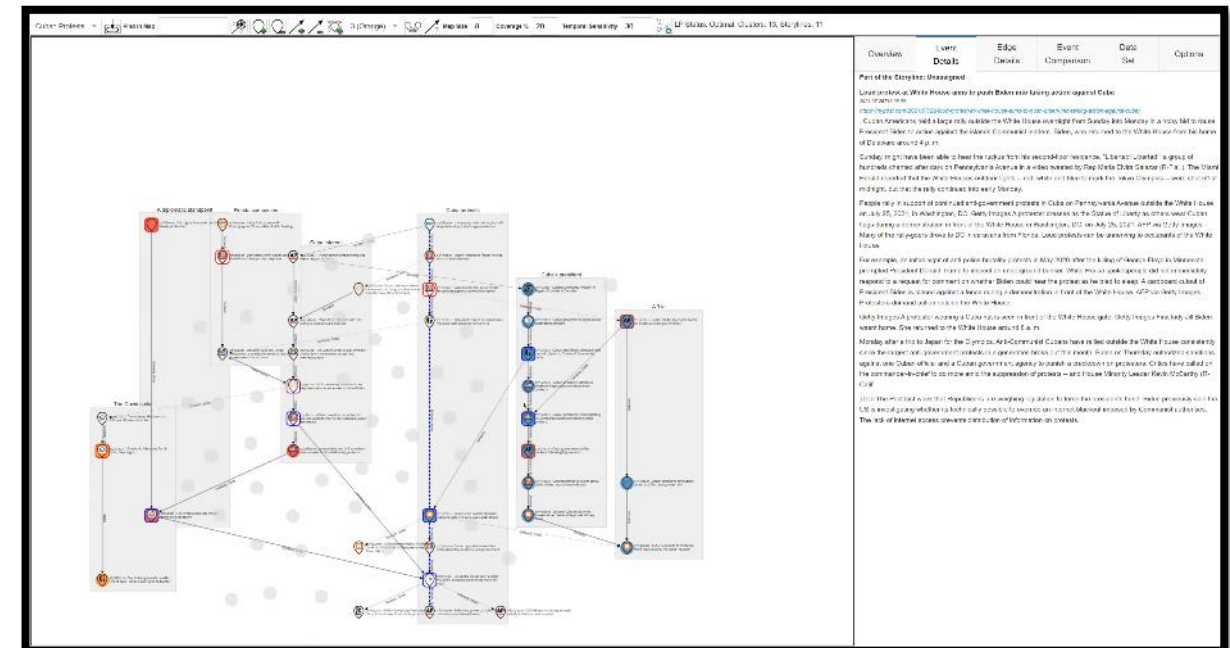
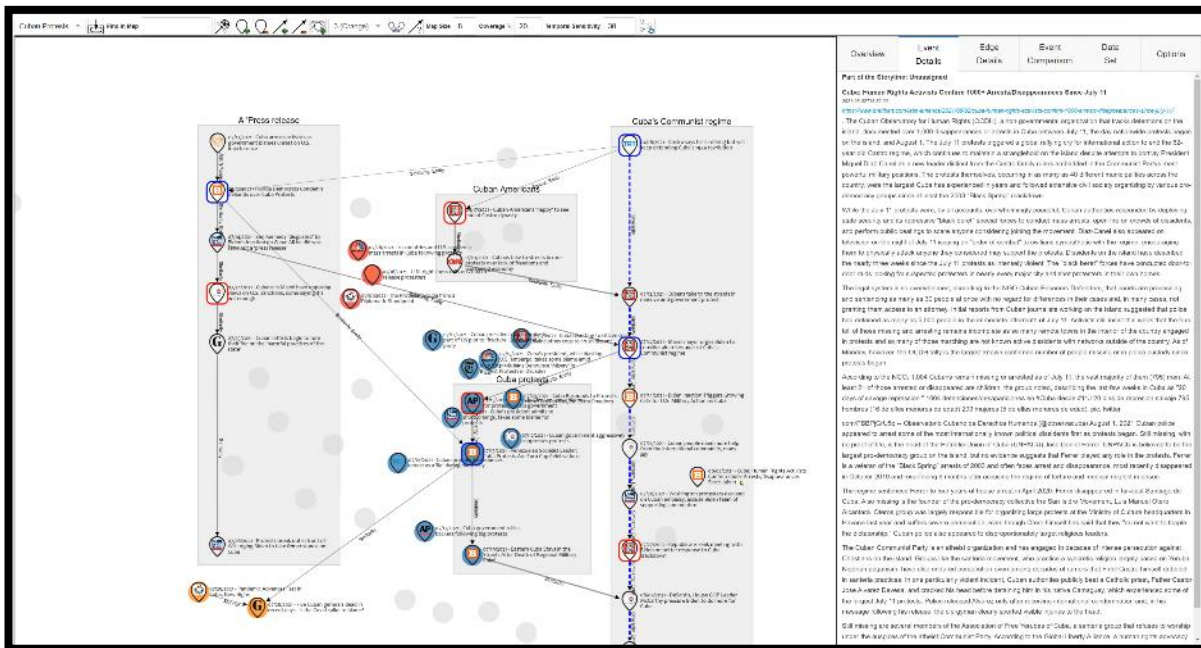

Conclusions

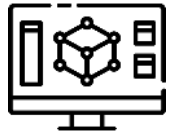

Narrative Sensemaking



Interactive AI Model



Scalability Issues

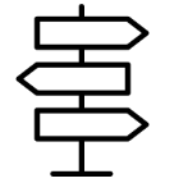

Interaction Ambiguity



Limitations



